



**MODELS
EST/EST TALL
SERVICE & PARTS MANUAL
Rev 1.08C 08-27-19**



BCINDUSTRIAL
YOUR HYGIENE PARTNER

2220 EASTMAN AVE. SUITE #112
VENTURA, CALIFORNIA 93003

(800) 577-6202

<https://bcichem.com>



TABLE OF CONTENTS

MODEL EST

1. SPECIFICATIONS	2
1.1 EST	2
2. GETTING STARTED	3
2.1. INTRODUCTION TO THE EST	3
2.2. RECEIVING AND INSTALLATION	4
2.2.1. <i>Electrical</i>	4
2.2.2. <i>Plumbing</i>	4
2.2.3. <i>Connecting the Scrap Accumulator and Drain</i>	5
3. OPERATION	6
3.1. INITIAL SETUP	6
3.2. STARTUP PROCEDURES.....	7
3.3. DAILY CLEANING PROCEDURES	7
3.4. QUICK SERVICE GUIDE.....	8
3.5. TROUBLESHOOTING.....	9
4. ADDENDUM FOR MACHINES INSTALLED IN THE CITY OF CHICAGO.....	11
5. PARTS MANUAL	12
5.1. INITIAL PARTS KIT (P/N 01100.84).....	12
5.1. OPTIONAL SANI ALARM	13
5.1. EXPLODED VIEW DRAWINGS.....	14
5.1.1. <i>Cabinet Assembly (EST/EST Tall)</i>	14
5.1.2. <i>Control Box Assembly</i>	15
5.1.3. <i>Door Actuator Assembly (EST/EST Tall)</i>	16
5.1.4. <i>Door Actuator Assembly for Corner EST/EST Tall</i>	17
5.1.5. <i>Pump Assembly</i>	18
5.1.1. <i>Plumbing System Assembly (Effective August 2012)</i>	19
5.1.2. <i>Plumbing System Assembly</i>	20
5.1.3. <i>Spray System Assembly (EST/EST Tall)</i>	21
5.1.4. <i>Power Drain Assembly</i>	22
5.1.5. <i>Power Drain Retrofit Kit p/n 00104.95</i>	23
5.1.6. <i>Peristaltic Pump Assembly</i>	24
5.1.7. <i>Temp – Sure Heater</i>	25
6. ELECTRICAL DIAGRAM	26

1. Specifications

1.1 EST	USA	METRIC
WATER CONSUMPTION		
PER RACK	1.13 GAL.	(4.28 L)
PER HOUR	41.7 GPH.	(158LPH)
OPERATING CYCLE		
WASH TIME-SEC.	53	53
RINSE TIME-SEC.	22	22
DWELL TIME-SEC.	15	15
TOTAL CYCLE	90 SEC.	90 SEC.
OPERATING CAPACITY		
RACKS PER HOUR	37	37
WASH TANK CAPACITY	1.13 GAL.	(4.28 L)
PUMP CAPACITY	52 GPM	(196.8 LPM)
WATER REQUIREMENTS		
REQUIRED MINIMUM TEMP.	120°F	(49°C)
RECOMMENDED TEMP.	140°F	(60°C)
WATER INLET	½"	1.27 cm
DRAIN CONNECTION	2"	5.1 cm
DIMENSIONS		
DEPTH	25 ¾"	(65.405 cm)
WIDTH	25 ¾"	(65.405 cm)
HEIGHT	55-56"	(140-142 cm)
MAX CLEARANCE FOR DISHES	17"	(43.18 cm)
STRANDARD RACKS	19 ¾" x 19 ¾"	(50 x 50 cm)
ELECTRICAL RATING		
	VOLTS	AMPS
	(60-Hz)	
	115	16
WASH PUMP MOTOR	1 HP	
SHIPPING WEIGHT		
APPROXIMATE	273#	(124 kg)

Note: The required flowing water pressure to the dishwasher is 15-65 PSIG. If pressures higher than 65 PSIG are present, a pressure regulating valve must be installed in the water line to the dishwasher (by others). If flowing pressure is lower than 15 psi, improper machine operation may result.



2. Getting Started

2.1. Introduction to the EST

The EST Dishmachine is safe and easy to operate with its “Auto Start/Stop” and it’s economical to operate—using only 1.25 gallons of water per cycle and less than 1900 watts of power when running. The EST Dishmachine’s top mounted controls include built-in chemical pumps and a deliming system that assures proper chemical usage. Its integrated scrap tray prevents food soil from entering the drain system. The EST can be run at a rate of 37 racks/148 covers per hour and its heavy-duty stainless steel construction assures long life and years of trouble free operation.

The EST is available for straight or corner applications.

This manual is structured to provide a complete reference guide to the EST Dishmachine. It is presented in a manner that all users will be able to comprehend and use as an effective tool in supporting the operation and maintenance of the dishmachine. The first section explains how the machine is packaged and what to look for when receiving the machine.

After unpacking the machine, this manual explains how to install and set up the machine for use. Requirements are given for plumbing, wiring, and space considerations. *These attributes of the machine are always taken into consideration by our well-trained sales representatives prior to the order being placed.* In the manual, guidance is also given for installation to ensure that the machine will be able to run at optimum conditions.

The Operation section of the manual may be used for instruction and procedures when required. We make this portion of the manual easy to understand so that all levels of operators may be able to read and comprehend the operation of the machine. The function of the machine itself is mostly automatic and takes little training to put into full operation. The Operation section also includes diagnostic considerations (troubleshooting) for the machine when problems occur.

The remaining sections of the manual—Parts Manual and Electrical Diagram—have the parts lists with exploded view drawings and the wiring diagram for the machine.

CMA warrants the workmanship of the machine.

We are committed to providing the best machines and customer service in the food industry and your feedback is welcome.

DISCLAIMER OF LIABILITY OF WARRANTY: CMA EXPRESSLY DISCLAIMS ANY AND ALL WARRANTIES, EXPRESS OR IMPLIED, RELATING TO THE INSTALLATION OF ANY AND ALL CMA EQUIPMENT THAT IS INSTALLED BY CHEMICAL DEALERS, CONTRACTED SERVICERS OR THIRD PARTY SERVICERS TO CMA EQUIPMENT. IF THE INSTALLATION INSTRUCTIONS ARE NOT FOLLOWED EXACTLY (TO THE LETTER), OR, IF ANY PERSON OR COMPANY CONDUCTING THE INSTALLATION OF THE CMA EQUIPMENT, REVISE THE INSTALLATION PROCEDURES OR ALTER THE INSTRUCTIONS IN ANY MANNER, THE CMA WARRANTY BECOMES VOID. IF, DUE TO THE IMPROPER INSTALLATION OF CMA EQUIPMENT, THIS EQUIPMENT CEASES TO OPERATE PROPERLY OR AFFECTS OTHER PARTS OF THE CMA DISHWASHING EQUIPMENT, IN THAT THE OTHER PARTS BECOME DEFECTIVE, THE CMA WARRANTY BECOMES VOID. CMA WILL NOT BE LIABLE OR RESPONSIBLE OR WARRANT CMA EQUIPMENT, DUE TO IMPROPER INSTALLATION OF ANY CMA MODEL DISHWASHER.

2.2. Receiving and Installation

The dishwasher is shipped from the factory in a corrugated box on a wooden pallet. The installation guidelines give a systematic procedure for setting up the machine.

Start by removing the dishmachine from the box. Remove the packaging, unwrap the machine and check for the following components:

- Inside the wash tank is a plastic bag with one control box key and a cam timer wrench.
- Tube stiffeners must be used to prevent the feed tubes from curling inside the chemical pail and sucking air. These are located on the outside of the machine with the chemical tubing already installed into the stiffeners. The ends of the chemical tubing have been flared so that the tubing will not pull out of the stiffener. Red is for detergent, white for sanitizer, and blue for rinse aid.

2.2.1. Electrical*

Prior to installation make sure the electrical supply is compatible with the specifications on the machines data plate.

The EST Dishmachine must be hard wired directly to a dedicated 115 VAC, 60Hz circuit equipped with proper circuit protection. The main power switch is at the top-right side of the control box.



DO NOT USE POWER CORD OR GFI OUTLET

This unit **MUST BE** hard-wired to a
dedicated appropriately size circuit breaker.

WARNING: Electrical and grounding connections must comply with the applicable portions of the National Electrical Code and/or other local electrical codes.

Note: For supply connections, use copper wire only rated at 90 degree C minimum.

2.2.2. Plumbing*

The water supply connection is made with a 1/2" hot water line to the water supply inlet on the top of the machine. The water supplied to the machine is recommended to be 140° F. The time necessary to deliver water to the machine is controlled by the number four cam. This cam

* **Electrical and plumbing connections must be made by a qualified person who will comply with all available Federal, State, and Local Health, Electrical, Plumbing and Safety codes**

Getting Started

provides the serviceman with the opportunity to fine tune the machine to deliver the proper amount of water with each cycle.

The EST Dishmachine has a 2" drain. The following section explains how to connect the drain.

Notice to Plumber: The plumber connecting this machine is responsible for making certain that the water lines are THOROUGHLY FLUSHED OUT BEFORE connecting to the dishwasher

Ask your municipal water supplier for details about your local water conditions prior to installation. Recommended water hardness is 3 grains per gallon or less.

Note: high iron levels in the water supply can cause staining and may require an iron filter. High chlorine levels in the water supply can cause pitting and may require a chloride removal system. If an inspection of the dishwasher or booster heater reveals lime buildup after the equipment has been in service, water treatment is recommended. If water softener is already in place, ensure there is a sufficient level of salt.

2.2.3. Connecting the Scrap Accumulator and Drain

The scrap accumulator is designed to perform two basic functions:

1. It allows a method to discharge all the heavy solids out of the machine with each wash cycle.
2. It provides accumulation capacity to allow draining the contents of one cycle regardless of the discharge rate of the existing drain.

The drainpipe is connected to the scrap accumulator drain using a 2" no-hub connector as shown in **Figure 2.2.3** below.

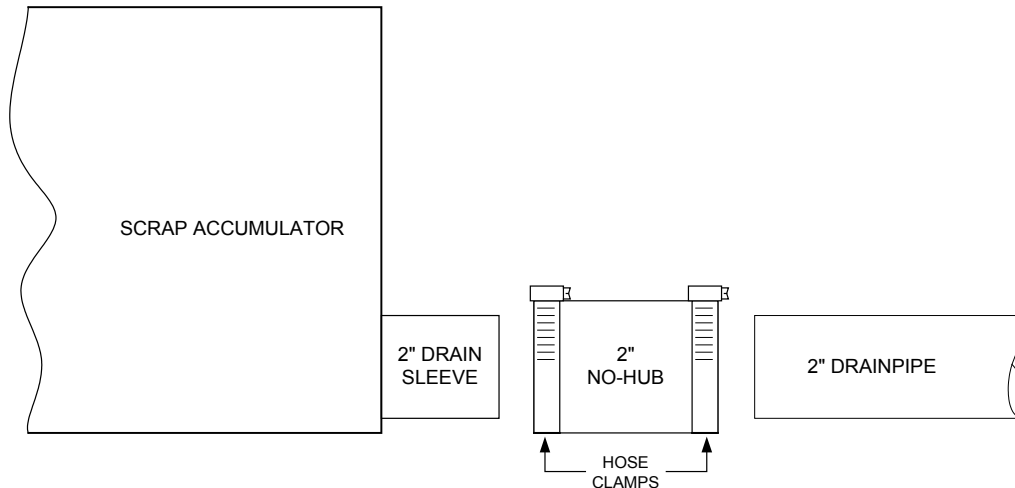

Figure 2.2.3

3. Operation

3.1. Initial Setup

All machines are equipped with switches to prime the peristaltic pumps at anytime the master switch is "ON".

Following completion of the installation, always fill the machine with water before starting the machine.

1. With the power "ON" hold the fill button until the water level overflows into the scrap accumulator.
2. Check the chemical lines to the chemical containers.
 - a. Red: detergent line.
 - b. Blue: rinse agent line.
 - c. Clear/White: sanitizers destainer line.
3. Activate the prime switches for the three chemical pumps until product is discharging into the machine.

Note: Use only commercial-grade detergents and rinse aids recommended by your chemical professional. Do not use detergents and rinse aids formulated for residential dishwashers.

Low Temperatures chemical-sanitizing dishmachines must not exceed 6% sodium hypochlorite solution (bleach) as the sanitizing agent. Higher levels may damage stainless or components.

Follow the directions precisely that are on the litmus paper vial and test the water on the surface of the bottom of the glasses. Concentration should be 50 p.p.m. minimum to 100 p.p.m. maximum. If concentration is incorrect contact your chemical supplier.

4. To start the machine, close the doors - this will automatically start the machine. The machine will run through its cycle.
5. Operate the machine one cycle and watch to ensure that the chemicals are delivered and stop during the cycle. Remember: red tube - detergent: blue tube - rinse: and clear/white tube - sanitizer. Check temperature at the end of the cycle for 140°F, 60°C.

The amount of product delivered by each cam is controlled by adjusting the cam's opening. When the micro switch rides down into the cam the peristaltic pump motor begins to rotate. It will continue to rotate until it rides up out of the groove.

Therefore, to extend the amount of product delivered to the machine, open the groove; to reduce the amount of product delivered to the machine, close the groove.

The cams are slip fit and a cam adjustment wrench is provided.

CAUTION: The motors on the new peristaltic pumps may be stalled by excessive tightening of the cover plate screws. If a peristaltic pump does not turn when the micro switch is activated, loosen the screws on the cover plate.

Technical personnel are available during normal business hours at CMA Headquarters should you, as an installer, have any questions please call **800-854-6417**.

3.2. Startup Procedures

Please follow the instructions given here before each shift to assure trouble free operation.

1. Drain the water if it is cold by activating the drain switch until all the water is out of the machine.
2. Check the drain screen and, if needed, remove it from the machine and clean it out. After cleaning, replace it properly into the sump housing.
3. Check the wash arm spray tips. If they are clogged, clean them with a toothpick and rinse them at the sink. Replace the wash arms..
4. Press and hold the fill switch until the water overflows into the scrap accumulator.
5. Once a proper water level is established, check the temperature of the water (it should be approximately 140°F, 60°C).
6. Insert the tray of dishes into the machine and close the doors. The machine will automatically start when the doors are closed.
7. After the machine stops, raise the doors, remove the tray of dishes and allow drying before stacking.

If the doors are lifted during a cycle, the machine will automatically stop running.

The EST will run through the wash and rinse cycles automatically feeding the proper chemicals and then turn itself off.

In an emergency you can turn off the machine by turning off the master switch located on the side of the control box.

3.3. Daily Cleaning Procedures

1. Remove scrap screen, clean off debris and flush with water.
2. Check power drain cavity and around drain support disc for trapped debris under diaphragm. Flush with water.
3. Replace scrap screen.
4. Remove spray arms, unscrew end plugs and flush with water.
5. Use toothpicks to push debris through spray jet orifice.

3.4. Quick service guide

MODELS: EST

TECHNICAL ISSUE	Cause	Solution
Machine starts while doors are open	Faulty magnetic door switch	Replace the switch, P/N 00557.55
	Faulty start/fill switch	Replace the switch, P/N 03470.01
Continuous cycles	Faulty #1 micro switch (start/stop)	Replace micro switch, P/N 00411.00
	Faulty start/fill switch	Replace micro switch, P/N 00411.00
	Faulty door switch	Replace the switch, P/N 00557.55
Wash motor runs continuously	Delimer switch in wrong position	Switch to <i>NORMAL</i> position
	Faulty delime switch	Replace the switch, P/N 00475.00
	Faulty motor contactor	Replace contactor, P/N 00404.82
Sanitizer pump does not run	Delimer switch on wrong position	Switch to <i>NORMAL</i> position
	Faulty delimer switch	Replace the switch, P/N 00475.00
	Faulty # 6 micro switch	Replace micro switch, P/N 411.00
	Faulty sanitizer pump motor	Replace the motor, P/N 00416.00
Drain valve does not operate	Broken Spring	Replace spring, P/N 00105.82
	Faulty #3 Micro switch	Replace micro switch, P/N 00411.00
	Faulty drain motor	Replace drain motor, P/N 00104.82
Machine does not fill	Faulty #4 micro switch (Fill)	Replace micro switch, P/N 00411.00
	Debris inside water solenoid valve	Clean valve replace diaphragm kit, P/N 00707.00
	Faulty start/fill switch	Replace the switch, P/N 03470.01
	Drain not closing	check function of drain sys.
	Faulty water solenoid coil/valve	Replace coil/valve, P/N 00738.10 or 03603.10
Water leaks out of vacuum breaker	Faulty check valve	Replace valve, P/N 00718.00
	Low incoming water pressure	Increase water pressure to 20 psi
	Faulty vacuum breaker kit	Replace vac. Brkr kit, P/N 03623.00
Machine only runs when start/fill switch is depressed	Faulty #1 micro switch (start/stop)	Replace micro switch, P/N 00411.00
	Faulty magnetic door switch	Replace door switch, P/N 00557.55
Will not start/ nothing works	Wall breaker tripped	Reset breaker
	Master on/off switch faulty or in off position	Reset or replace switch, P/N 00471.10
Runs, but none of the other functions engage	Faulty #2 Micro switch (cycle reset)	Replace micro switch, P/N 411.00
	Faulty ice cube relay (yellow relay)	Replace relay, P/N 00636.00

3.5. Troubleshooting

PROBLEM	LIKELY CAUSE	SOLUTION
Machine inoperative	Power off at circuit breaker	Reset circuit breaker
	Defective power switch	Replace power switch P/N: <u>00471.10</u>
Motor inoperative	Door is not fully closed	Close door
	Defective door safety switch	Replace door safety switch P/N: <u>00562.00</u>
	Defective timer assembly	Replace timer assembly* P/N: <u>00407.83</u>
	Defective pump motor contactor	Replace contactor P/N: <u>00404.82</u>
	Defective motor	Replace motor P/N: <u>00201.00</u>
	Defective Delime-Off-Normal Switch	Replace Toggle switch P/N: <u>00475.00</u>
Motor runs with door open	Defective door safety switch	Replace door safety switch P/N: <u>00562.00</u>
	Defective pump motor contactor	Replace contactor P/N: <u>00404.82</u>
Water temperature below 120° F.	Low incoming water temperature	Turn up supply water heater Insulate supply water pipe
	Cold water mixing with supply	Isolate hot water from cold water
	Defective thermometer (actual temperature is okay)	Replace thermometer P/N: <u>03202.00</u>
Low rinse water flow	Limed up rinse arm spray nozzles	Delime rinse arm nozzles
No rinse water flow	Defective water solenoid valve	Replace water solenoid valve P/N: <u>03603.10</u>
Rinse water runs with door open	Defective door safety switch	Replace door safety switch P/N: <u>00562.00</u>
With power on, activating start switch does not begin cycle	Defective fill/start switch (running light will not light either)	Replace toggle switch P/N: <u>03470.01</u>
	Defective timer assembly	Replace timer assembly* P/N: <u>00407.83</u>

*The timer assembly motor (P/N: 00407.83) or micro switches (P/N: 00411.00) can be replaced independently if that's the only component that's failed.

Operation

PROBLEM	LIKELY CAUSE	SOLUTION
Start switch requires more than one second activation to run cycle	Defective (Instant Start) ice cube relay	Replace ice cube relay P/N: <u>00631.00</u>
Activating fill switch does not fill machine	Defective water solenoid valve	Replace water solenoid valve P/N: <u>03603.10</u>
	Defective fill/start switch	Replace toggle switch P/N: <u>03470.01</u>
Fill (rinse water) won't shut off	Defective water solenoid valve	Replace water solenoid valve P/N: <u>03603.10</u>
	Defective fill/start switch	Replace toggle switch P/N: <u>03470.01</u>
	Defective timer assembly	Replace timer assembly* P/N: <u>00407.83</u>
Activating drain switch does not drain machine	Defective rinse prime/drain switch	Replace toggle switch P/N: <u>03470.00</u>
	Defective drain motor	Replace drain motor P/N: <u>00104.82</u>
Running light does not light while motor runs	Defective running light	Replace running light P/N: <u>00406.00</u>
Wrong temperature is displayed	Defective thermometer	Replace thermometer P/N: <u>03202.00</u>
Machine won't hold water	Foreign object caught in drain	Remove foreign object
Scrap tray overflowing	Scrap tray clogged	Clean out scrap tray
	Drain plugged	Unplug drain

*The timer assembly motor (P/N: 00407.83) or micro switches (P/N: 00411.00) can be replaced independently if that's the only component that's failed.



4. Addendum for Machines Installed in the City of Chicago

"All food dispensing establishments using chlorine or other approved chemical sanitizers shall, at all times, maintain an adequate testing device."

"Dishes and other eating and drinking utensils to be washed in a dishwashing machine shall be properly scraped and pre-rinsed and shall be stacked in racks or trays so as to avoid overcrowding, and so as to permit the wash and rinse waters to reach all surfaces of each utensil."

"In machine washing, multi-use eating and drinking utensils shall be washed in water containing a suitable detergent at a temperature from 120 degrees F. to 140 degrees F. or other method approved by the Department of Health.

"The water in the wash tank shall be changed during operation as often as is necessary to keep it reasonably clean. An effective concentration of detergent in the wash water shall be maintained at all times."

"Bactericidal treatment shall consist of exposure of all surfaces of dishes and utensils being washed to a rinse of clean water, at a temperature of not less than 180 degrees F. or other method approved by the Department of Health."

"All dishwashing machines shall maintain a flow pressure not less than 15 or more than 25 pounds per square inch on the fresh water line at the machine and not less than 10 pounds per square inch at the rinse nozzles. A suitable gauge cock shall be provided immediately upstream from the final rinse spray to permit checking the flow of the final rinse water. An easily readable thermometer accurate to ± 2 degrees F. shall be provided on both the wash and rinse water lines of the dishwashing machine which will indicate the temperature of the water solution therein."

"Dishwashing machines shall be thoroughly cleaned at least once each day. The pumps and the wash and rinse sprays or jets shall be so designed that a forceful stream of water will reach all surfaces of the utensils when they are properly racked. These parts shall be thoroughly cleaned at least once each day. The pumps and the wash and rinse sprays or jets shall be so designed that a forceful stream of water will reach all surfaces of the utensils when they are properly racked. These parts shall be readily accessible for inspection and cleaning."

"After bactericidal treatment, utensils and containers shall be stored at a sufficient height above the floor in a clean, dry place, protected from flies, splash, dust, overhead leakage and condensation, and other contamination. Containers and utensils shall be inverted, covered, or otherwise protected from contamination until used for serving."

Drain racks, trays, and shelves shall be made of non-corrodible material and shall be kept clean.

In handling containers and utensils the surfaces thereof which come in contact with food or drink shall not be touched by the hands, except during the process of washing.

Tables for clean and dirty dishes and food shall be so arranged that the dirty dishes will be as far removed from the food and clean dishes as may be possible.

All single-service articles and utensils shall be purchased in sanitary cartons and stored therein in a clean, dry place until used, and after removal from the cartons, these articles shall be handled in such a manner as to prevent contamination.

Please note the following procedures must be followed for City of Chicago Approval:

- 1. All low energy models must have low level sani alarms, both visual and audio.**
- 2. All models must have a City of Chicago approval data label affixed to the machine.**
- 3. Chlorine sanitizer must be a minimum of 100 PPM.**

5. Parts Manual

5.1. Initial Parts Kit (P/N 01100.84)

P/N	DESCRIPTION	Qty
00104.50	Drain Motor, 120V 60Hz	1
00108.83	Drain Actuator Arm (V)	1
00109.60	Drain Actuator Shaft (V)	1
00115.87	Drain Screen	1
00120.02	Thermometer	1
00121.60	Drain Diaphragm	1
00200.10	Pump Assembly, 110/220V 60Hz	1
00206.30	Pump Seal Kit	1
00304.06	Spray Arm	1
00308.50	Spray Arm End Plug, SS	1
00341.00	Spray Arm Bearing	1
00406.00	Control Box Light, .5" Diameter, Red	1
00407.83	Timer, 90 Sec, 8 Cam	1
00416.00	Peristaltic Pump Assembly, 120V/60Hz	1
00425.51	Chemical Tubing Blue	1
00425.53	Chemical Tubing Red	1
00425.54	Chemical Tubing White	1
00470.10	Toggle Switch Rubber Boot	3
00471.10	Toggle Switch, Off/On, 20-Amp	1
00475.00	Toggle Switch, DPDT, 15-Amp, Delimer	1
00562.00	Door Limit Switch, Roller Action	1
00602.00	Door Spring	1
00631.00	Ice Cube Relay, 120V	1
00707.00	1/2" Water Solenoid Repair Kit, JE	1
00738.10	Solenoid Coil, JE, 120V (3/4" & 1/2")	1
00938.82	1/2" Drain Bushing, Brass (V)	2
00966.10	10-32X1/4 Hexhead SS Bolt	1
02257.00	Squeeze Tube Norprene	1
03415.45	Flex-Tight Fitting	1
03470.00	Toggle Switch, Momentary, Screw Terminals	1
03623.00	1/2" Vacuum Breaker Repair Kit, Watts	1
04103.14	Drain Valve Spring	1

5.1. Optional Sani Alarm

Part Number 12508.00

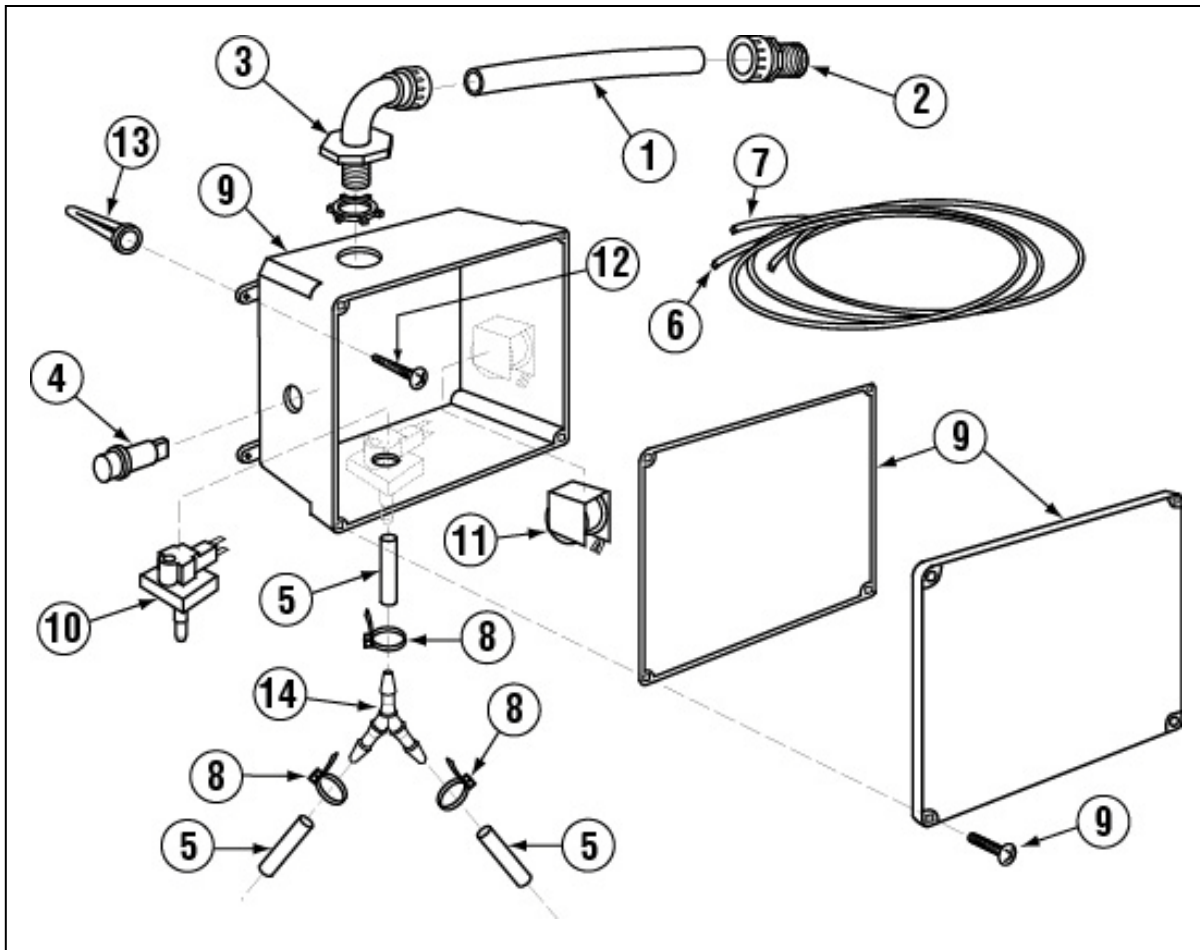

Exploded View

ITEM NO.	NO. REQ'D	P/N	DESCRIPTION
1	3	00400.00	Conduit, 3/8" Sealtite
2	1	00401.00	S.T. 3/8" Straight Connector
3	1	00402.00	S.T. 90 Degree 3/8" Connector
4	1	00406.00	Control Box Light, .5" Diameter, Red
5	1	00435.00	Squeeze Tube, 8"
6	1	00521.00	Wire, 18 Gauge, Orange, 6 ft.
7	1	00531.00	Wire, 18 Gauge, White, 6 ft.

ITEM NO.	NO. REQ'D	P/N	DESCRIPTION
8	5	00931.00	Wire Tie, Small
9	1	12510.00	Sanitizer Alarm Box Assembly
10	1	12511.50	Sanitizer Low Level Vacuum Switch
11	1	12512.00	Sanitizer Alarm Buzzer, 120 Volts
12	4	40126.10	#10 x 3/4" Sheet metal Screw
13	4	40127.00	Wall Anchors
14	1	00426.00	Y Hose Connector, 3/16"

5.1. Exploded View Drawings

5.1.1. Cabinet Assembly (EST/EST Tall)

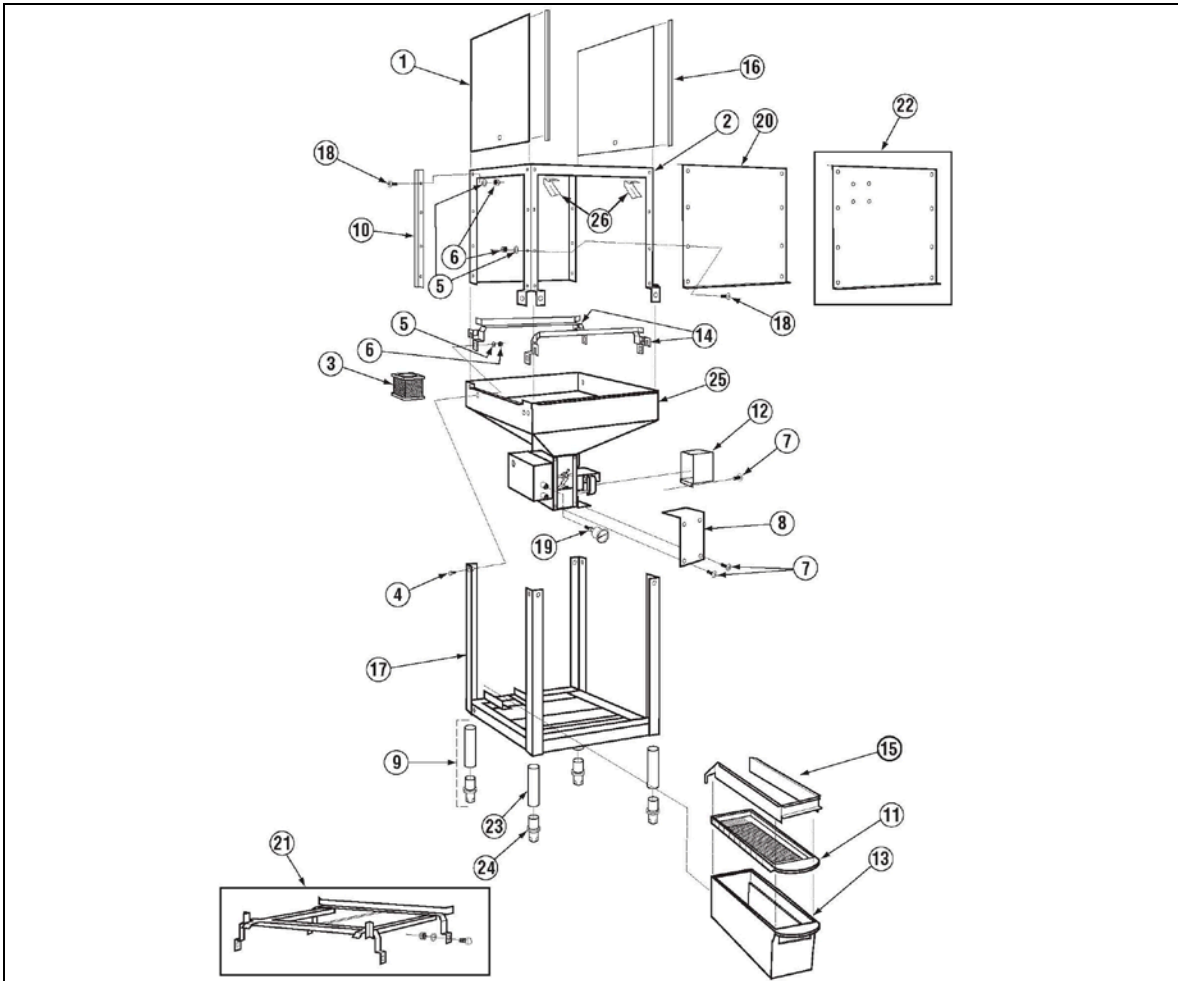

ITEM NO.	NO. REQ'D	P/N	DESCRIPTION
1	2	01506.30	Door (Standard Stamped)
		01506.10	Door (Pizza) Dimple Stamped
2	1	01510.50	Wrapper 3 Door EST (2010)
		01510.43	Wrapper EST-Tall (2010)
3	1	00115.87	Drain Screen
4	18	00906.00	1/4-20 x 1/2" Hex head Bolt
5	60	00924.00	1/4" SS Washer
6	40	00912.00	1/4-20 Nylon Lock Nut
7	6	00940.50	10-32 x 3/8" Truss Head Screw
8	1	00120.40	EVA Power Drain Cover
9	4	01145.00	Leg Ass'y 10" wAdjustable Socket
10	4	01554.30	Ez Glide Door Guide SS 21 1/8"
		17554.00	CMA-180 Door Guide 26-3/8"
11	1	01577.21	S/S Scrap Trap Drawer
12	1	01573.30	Sani Mount/Drain Lid
13	1	01577.10	Scrap Trap Body

ITEM NO.	NO. REQ'D	P/N	DESCRIPTION
14	2	01505.32	Tray Track, Inline
15	1	01579.50	EVA Splash Card
16	4	00636.10	EZ Glide Door Guide Sq 21-7/8"
		00636.15	EZ Glide Door Guide 25-7/8"
17	1	01502.95	EST Stand
18	16	00905.00	1/4-20 x 1/2" Truss Head Bolt
19	1	00120.02	Thermometer (Bi Metal)
20	1	01540.40	Wrapper Panel E-AH/EST w/o holes
		01540.44	Wrapper Panel E-EVA AH Tall
21	1	01505.10	Tray Track, Corner
22	1	01540.39	Wrapper Panel EVA-C
		01540.43	Wrapper Panel EVA-C Tall
23	4	01572.10	SS Leg
24	4	01310.00	Bullet Foot
25	1	1502.90	EST Pan
26	1	03415.72	Detergent /Rinse Fitting Bracket

5.1.2. Control Box Assembly

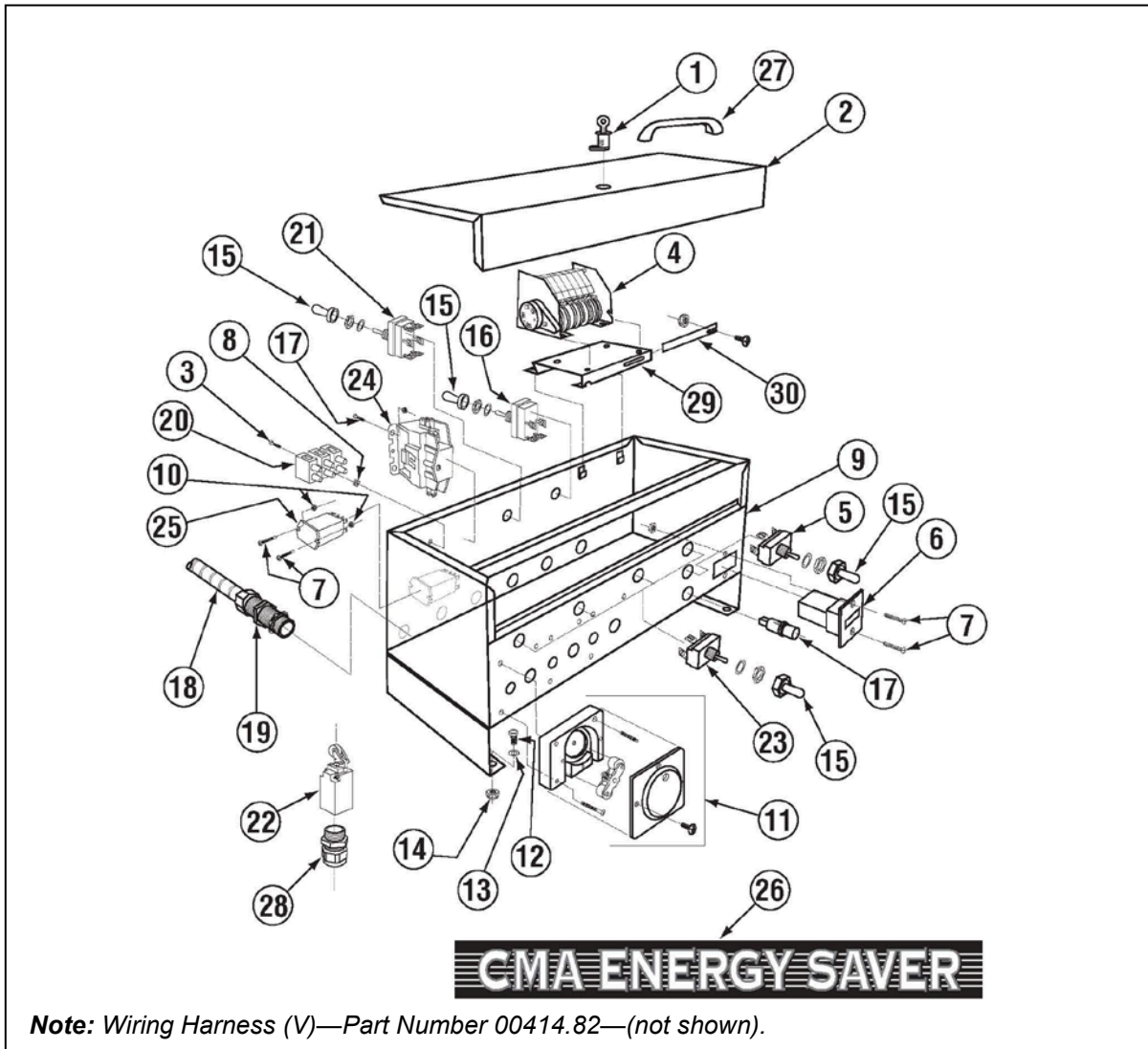

ITEM NO.	NO. REQ'D	P/N	DESCRIPTION
1	1	00449.00	Lock and Key
2	1	01504.17	Control Box Lid
3	5	00911.50	8-32 x 3/8" Pan Head Screw
4	1	00407.83	Timer, 90 Seconds
5	1	03470.01	Toggle Switch, Momentary
6	1	03408.50	Counter (Face Mount)
7	4	00907.00	6-32 x 1/2" SS Pan Head Screw
8	4	00917.00	8-32 PM Nut
9	1	01503.19	Control Box Body
10	4	00916.00	6-32 pm nut
11	3	00415.00	Peristaltic Pump Assembly*
12	4	00906.00	1/2-20 x 1/2" Hex Head Bolt
13	4	00924.00	1/4" SS Washer
14	4	00912.00	1/4-20 Nylon Lock Nut
15	5	00470.10	Toggle Switch Boot

ITEM NO.	NO. REQ'D	P/N	DESCRIPTION
16	1	00471.10	Toggle Switch Off/On 20 Amp
17	2	00406.00	Control Box Light, 120V, 60Hz
18	1	00400.00	Conduit, 3/8" Sealtite
19	3	00401.00	S.T. 3/8" Straight Connector
20	1	00454.10	3-Pole Socket Terminal Block
21	1	00475.00	Toggle Switch, 15 Amp
22	1	00562.00	Door Limit Switch, Roller Action
23	4	03470.00	Toggle Switch
24	1	00404.82	Contacting Relay
25	1	00631.00	Ice Cube Relay
26	1	06232.25	CMA Energy Saver Label
27	1	00535.00	Control Box Lid Handle
28	1	00562.60	Connector, #562 Door Limit Switch
29	1	01503.18	Control Box (E/EST) Timer Mount
30	1	01514.17	Timer Support Tab (E/EST) 2010

*See section 5.1.6 Peristaltic Pump Assembly for details

5.1.3. Door Actuator Assembly (EST/EST Tall)

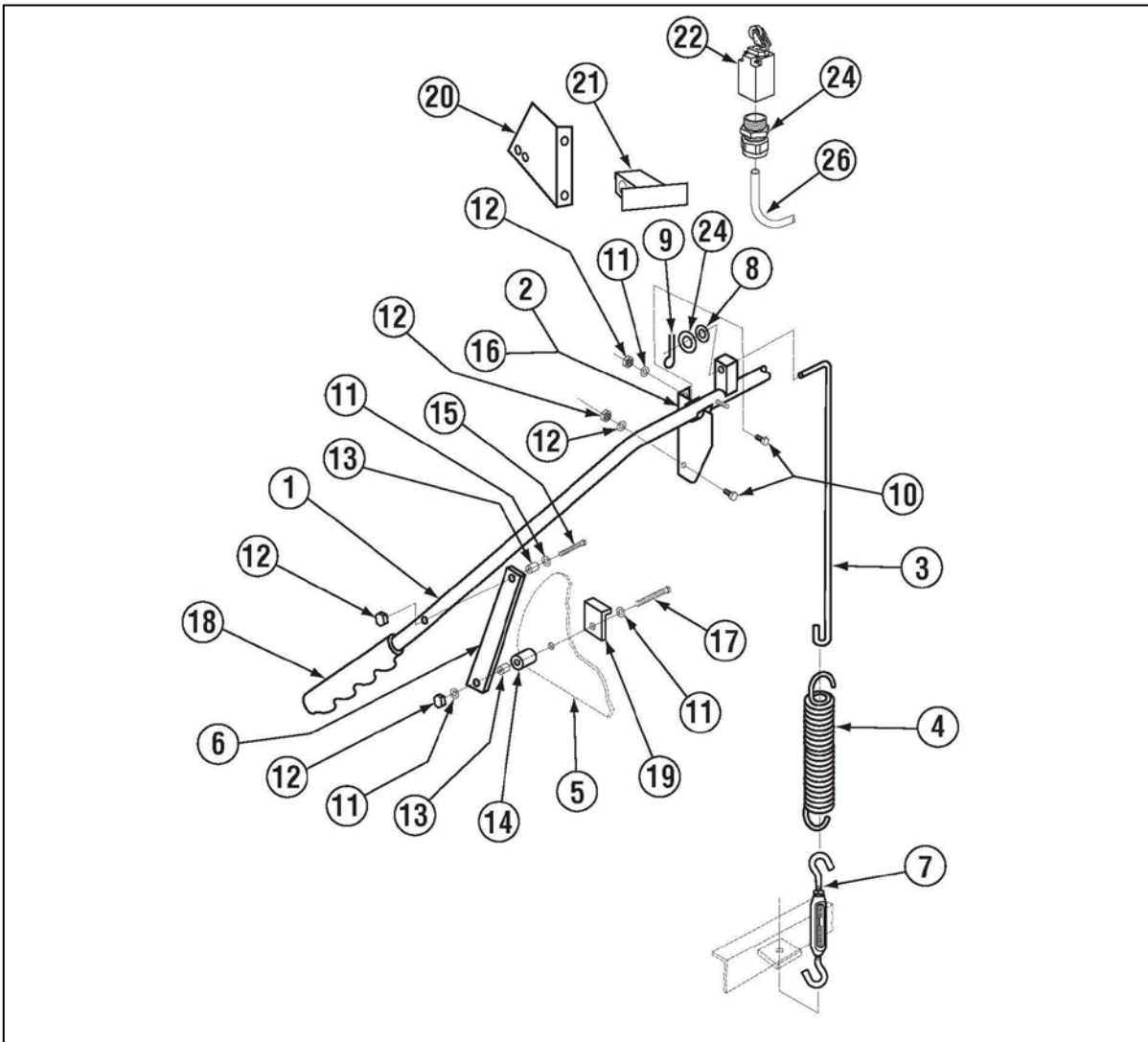

ITEM NO.	NO. REQ'D	P/N	DESCRIPTION
1	1	00613.32	Door Handle, 1" (Model AH)
2	1	01556.50	Door Handle Support, 1" (Right)
3	2	00603.07	Door Spring Extension Rod
4	2	00602.00	Door Spring (# 602.20 B & S models)
5	2	01506.30	Door (Cut Away)
6	2	01553.00	Door Handle Link
7	2	00606.50	Turn Buckle
8	2	00926.00	5/16" SS Washer
9	2	00900.00	Cotter Pin
10	4	00906.00	1/4-20 x 1/2" Hex Head Screw
11	6	00924.00	1/4" SS Washer
12	8	00912.00	1/4-20 Nylon Locknut
13	4	00610.00	Door Handle Spacer, Small

ITEM NO.	NO. REQ'D	P/N	DESCRIPTION
14	4	00611.00	Door Handle Spacer, Large
15	2	00910.00	1/4-20 x 1-1/2" Hex Bolt
16	1	01555.50	Door Handle Support, 1" (Left)
17	2	00903.00	1/4-20 x 1-3/4" Hex Head Bolt
18	2	00607.04	Door Handle Cap, 1"
19	2	01552.00	Door Stop
20	1	00563.40	Door Switch Bracket (8-08)
21	1	00563.42	Door Switch Actuator (8-08)
22	1	00562.00	Roller Door Switch
23	1	00562.60	Connector Door Roller Switch
24	1	00605.30	Door Rod Spacer
25	1	00546.00	18 AWG Switch Cord

5.1.4. Door Actuator Assembly for Corner EST/EST Tall

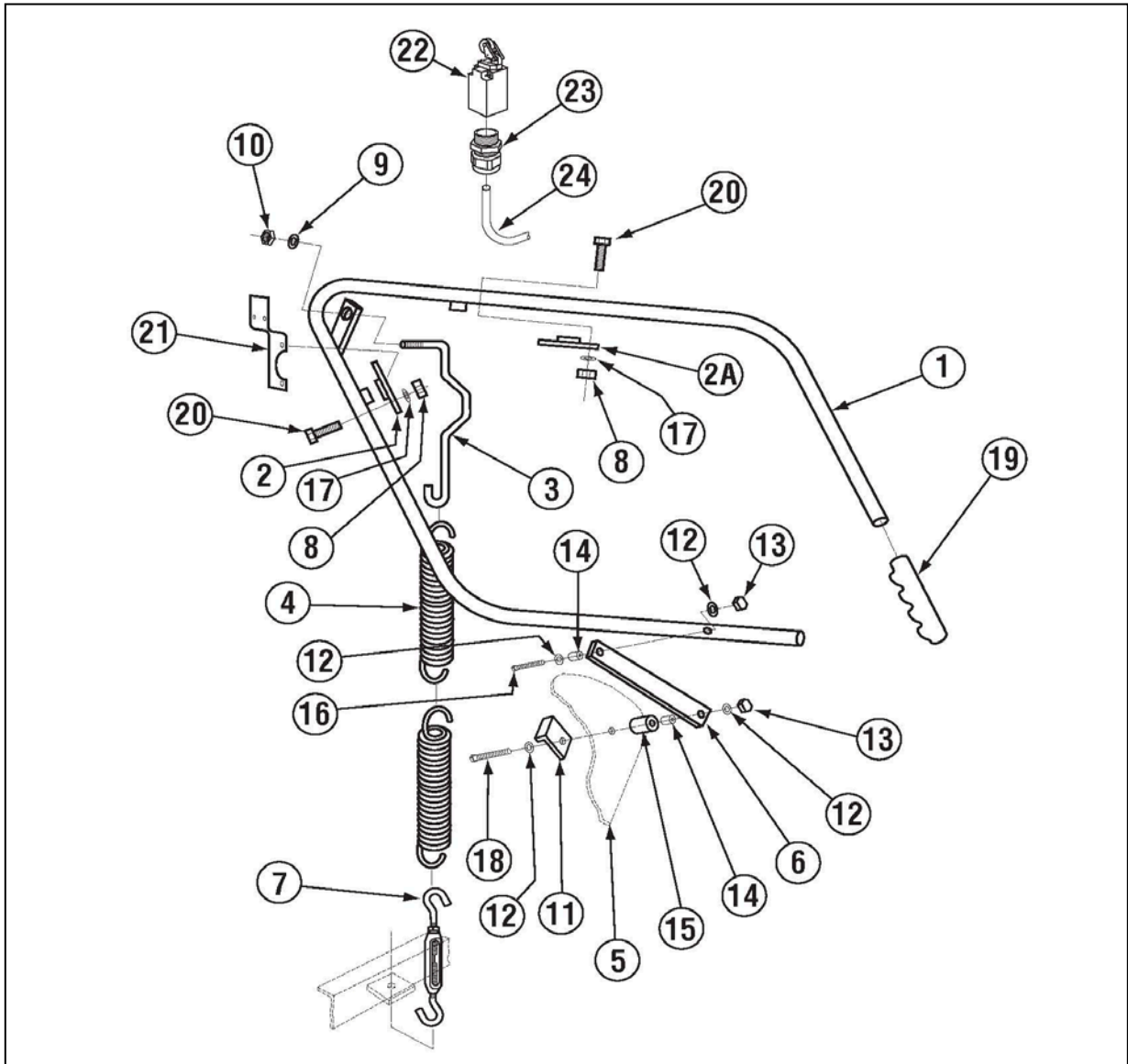

ITEM NO.	NO. REQ'D	P/N	DESCRIPTION
1	1	00613.44	Door Handle
2	1	00619.34	Door Handle Mounting Plate, Long
2A	1	00619.44	Door Handle Mounting Plate, Short
3	1	00603.86	Extension Rod
4	2	00602.00	Door Spring (# 602.20 Tall model)
5	2	01506.30	Door (Cut Away)
6	2	01553.00	Door Handle Link
7	2	00606.50	Turn Buckle
8	9	00913.00	5/16-18 Nut
9	9	00926.00	5/16 SS Washer
10	1	00900.00	Cotter Pin
11	2	01552.00	Door Stop
12	6	00924.00	1/4" SS Washer

ITEM NO.	NO. REQ'D	P/N	DESCRIPTION
13	4	00912.00	1/4-20 Nylon Lock Nut
14	4	00610.00	Door Handle Spacer, Small
15	4	00611.00	Door Spacer, Large
16	2	00903.00	1/4-20 x 1-3/4" Hex Head Bolt
17	8	00926.00	5/16" SS Washer
18	2	00910.00	1/4-20 x 1-1/2" Hex Head Screw
19	2	00607.04	Door Handle Cap
20	8	00920.00	5/16-18 x 3/4" Hex Head Bolt
21	1	00563.30	Limit Switch Door Bracket
22	1	00562.00	Roller Door Switch
23	1	00562.60	Connector Door Roller Switch
24	1	00546.00	18 AWG Switch Cord

5.1.5. Pump Assembly

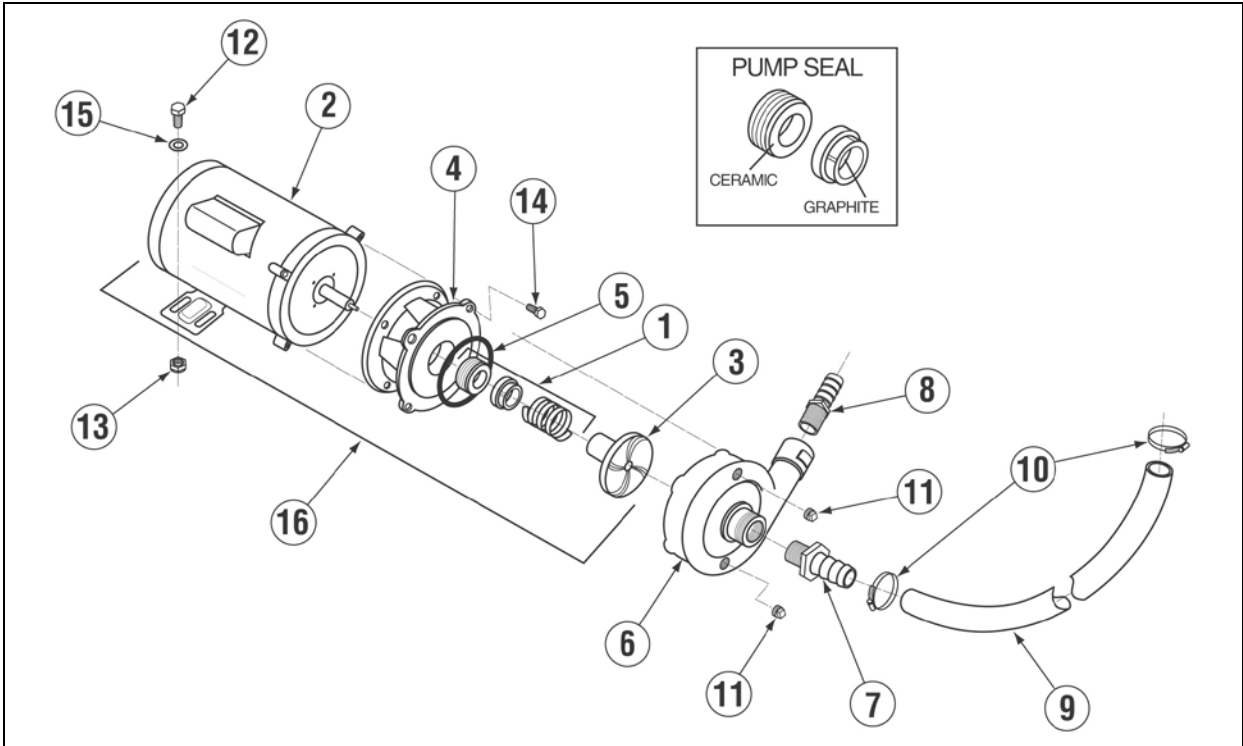

ITEM NO.	NO. REQ'D	P/N	DESCRIPTION
1	1	00206.30	Pump Seal Kit
2	1	00201.00	Pump Motor 1Hp 115/208-230V
3	1	03222.10	Impeller (Universal) Open
4	1	04207.10	Pump Base
5	1	03226.00	Pump O Ring Gasket
6	1	04207.20	Pump Cover
7	1	50302.40	1 1/4" MIP X 1" Barb Fitting
8	1	50302.06	1" MPT X 1" Barb PVC Sch 80

ITEM NO.	NO. REQ'D	P/N	DESCRIPTION
9	1	03108.61	Transfer Hose 1"
10	2	03101.00	Hose Clamp # 16 1"
11	2	00238.00	3/8 Male Plug
12	1	00906.00	1/4-20 X 1/2 Hexhead Bolt
13	1	00912.00	1/4-20 Nylon Lock Nut
14	4	00921.00	3/8-16 X 3/4 SS Hexhead Bolt
15	1	00924.00	1/4 SS Washer
16	1	00200.10	Pump Assy 110/220V 60Hz open

5.1.1. Plumbing System Assembly (Effective August 2012)

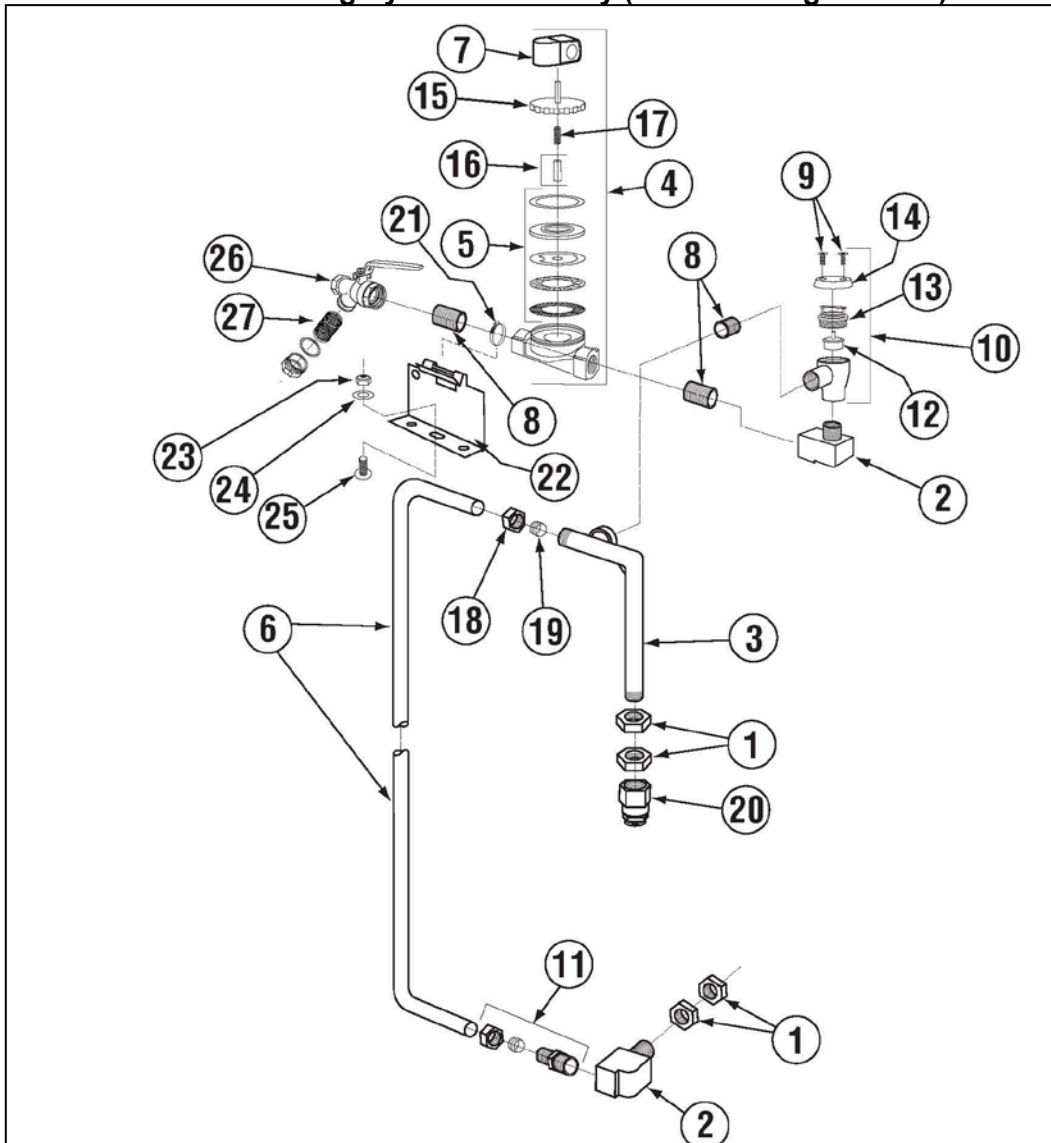

ITEM NO.	NO. REQ'D	P/N	DESCRIPTION
1	4	00721.00	1/2" Jamb Nut
2	2	00745.00	1/2" Street Elbow
3	1	00770.00	Water Inlet Elbow Assy
4	1	03603.10	1/2" Water Solenoid Assembly, J/E*
5	1	00707.00	1/2" Water Solenoid Repair Kit
6	1	00796.20	Flush Tube
7	1	00738.10	Water Solenoid Coil
8	2	00742.00	1/2" x 1-1/2" Brass Nipple
9	2	00421.51	6-32 x 1/4" Pan Head Screw
10	1	03624.00	Vacuum Breaker Assembly, Watts**
11	1	00760.00	5/8" Compression x 1/2" MIP Adapter
12	1	03623.00	1/2" Vacuum Breaker Repair Kit
13	1	03624.25	1/2" Vacuum Breaker Bonnet, Brass
14	1	00739.50	Vacuum Breaker Cap, SS (fits 1/2" or 3/4")

ITEM NO.	NO. REQ'D	P/N	DESCRIPTION
15	1	03603.20	1/2" Water Solenoid Bonnet
16	1	00786.00	Water Solenoid Valve Plunger w/Spring
17	1	00706.10	Valve Plunger, Spring Only
18	1	00770.10	5/8" Compression Fitting Nut
19	1	00770.20	5/8" Compression Fitting Ring
20	1	00748.00	Sprinkler Head
21	1	03101.45	Hose Clamp #4 Size #002 SS
22	1	14508.50	Plumbing Bracket
23	1	03801.00	10-32 Lock Nut
24	2	00924.00	1/4 SS Washer
25	1	00940.50	10-32 x 3/8 Truss Head Screw
26	1	41062.00	1/2 Strainer Ball Valve NPT
27	1	41062.10	1/2 Ball Valve Strainer Only

5.1.2. Plumbing System Assembly

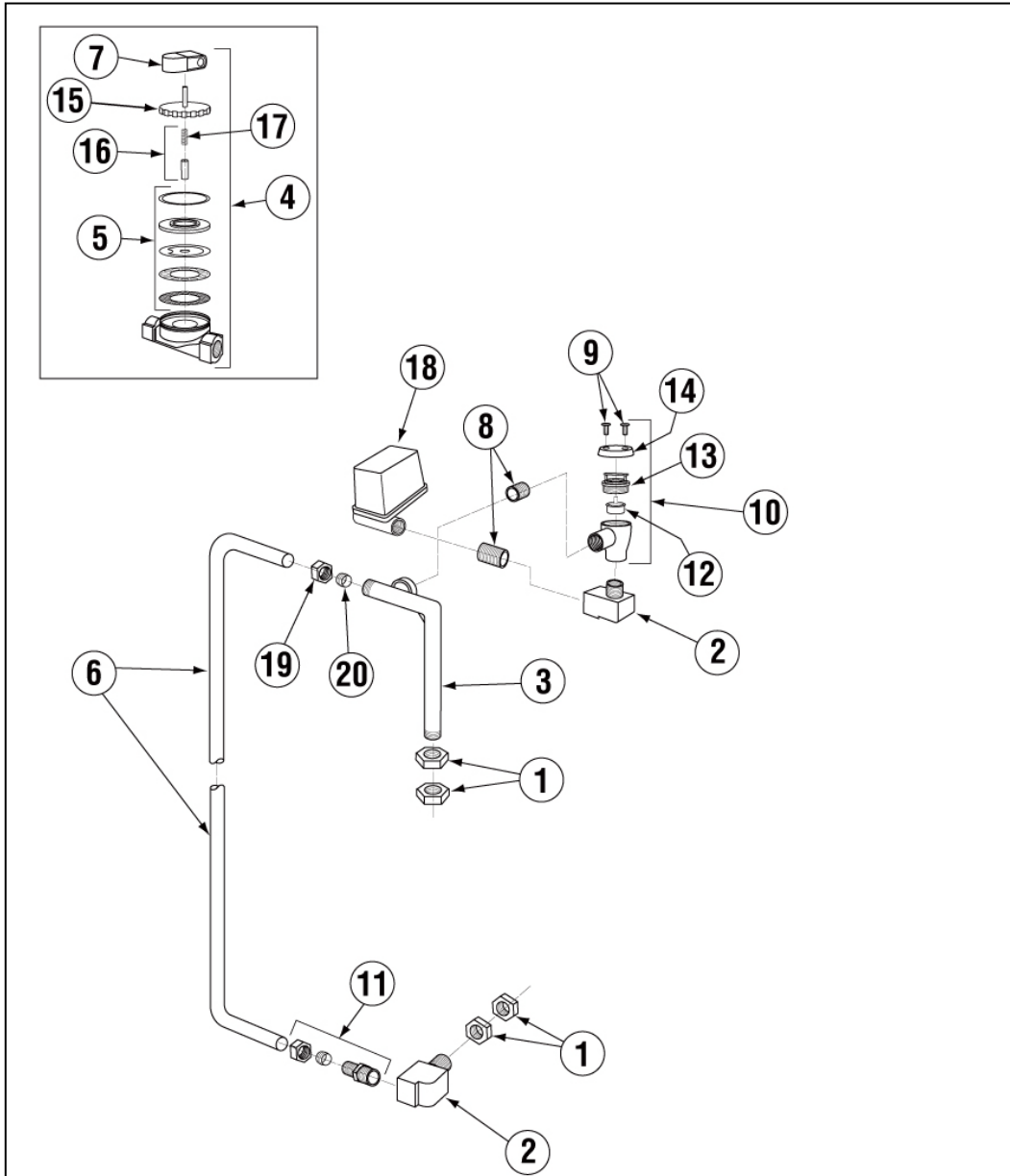

ITEM NO.	NO. REQ'D	P/N	DESCRIPTION
1	4	00721.00	1/2" Jamb Nut
2	2	00745.00	1/2" Street Elbow
3	1	00770.00	Water Inlet Elbow Assy
4	1	03603.10	1/2" Water Solenoid Assembly, J/E*
5	1	00707.00	1/2" Water Solenoid Repair Kit
6	1	00796.20	Flush Tube
7	1	00738.10	Water Solenoid Coil
8	2	00742.00	1/2" x 1-1/2" Brass Nipple
9	2	00421.51	6-32 x 1/4" Pan Head Screw
10	1	03624.00	Vacuum Breaker Assembly, Watts**

ITEM NO.	NO. REQ'D	P/N	DESCRIPTION
11	1	00760.00	5/8" Compression x 1/2" MIP Adapter
12	1	03623.00	1/2" Vacuum Breaker Repair Kit
13	1	03624.25	1/2" Vacuum Breaker Bonnet, Brass
14	1	00739.50	Vacuum Breaker Cap, SS (fits 1/2" or 3/4")
15	1	03603.20	1/2" Water Solenoid Bonnet
16	1	00786.00	Water Solenoid Valve Plunger w/Spring
17	1	00706.10	Valve Plunger, Spring Only
18	1	03604.00	SS Water Solenoid Valve 1/2"
19	1	00710.10	5/8" Compression Fitting Nut
20	1	00710.20	5/8" Compression Fitting Ring

5.1.3. Spray System Assembly (EST/EST Tall)

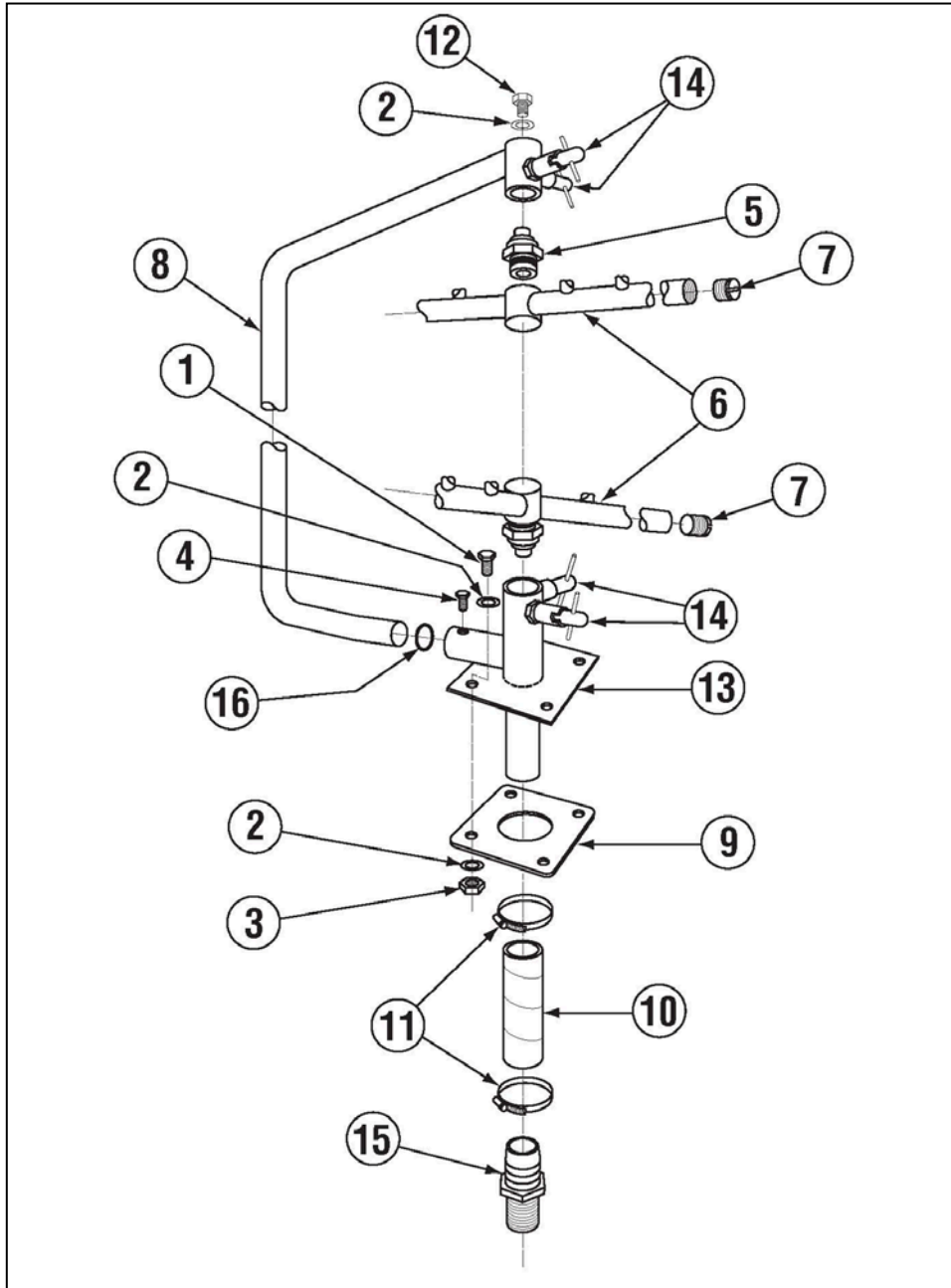

ITEM NO.	NO. REQ'D	P/N	DESCRIPTION
1	4	00914.00	1/4-20 x 3/4" Hex Head Bolt
2	9	00924.00	1/4" SS Washer
3	4	00912.00	1/4-20 Nylon Lock Nut
4	1	00966.10	10-32 x 1/4" Hex Head SS Bolt
5	2	00341.00	Spray Arm Bearing
6	2	00304.07	Spray Arm A/C Series
7	4	00308.50	Spray Arm End Plug SS
8	1	00305.20	Spray Manifold, EST/N- EVA

ITEM NO.	NO. REQ'D	P/N	DESCRIPTION
9	1	04306.00	Square Manifold Gasket
10	1	03108.61	Transfer Hose 1"
11	2	03101.00	Hose Clamp
12	1	00905.82	1/4-20 x 3/8" Truss Head Bolt
13	1	00357.20	Lower Spray Base, N EVA 2007
14	4	0363.50	Spray Base Pull Lock Pin
15	1	50302.06	1" MPT X 1" Barb PVC Schedule 80
16	1	00302.84	Spray Base O-Ring, E-VA

5.1.4. Power Drain Assembly (Prior to 11-2007)

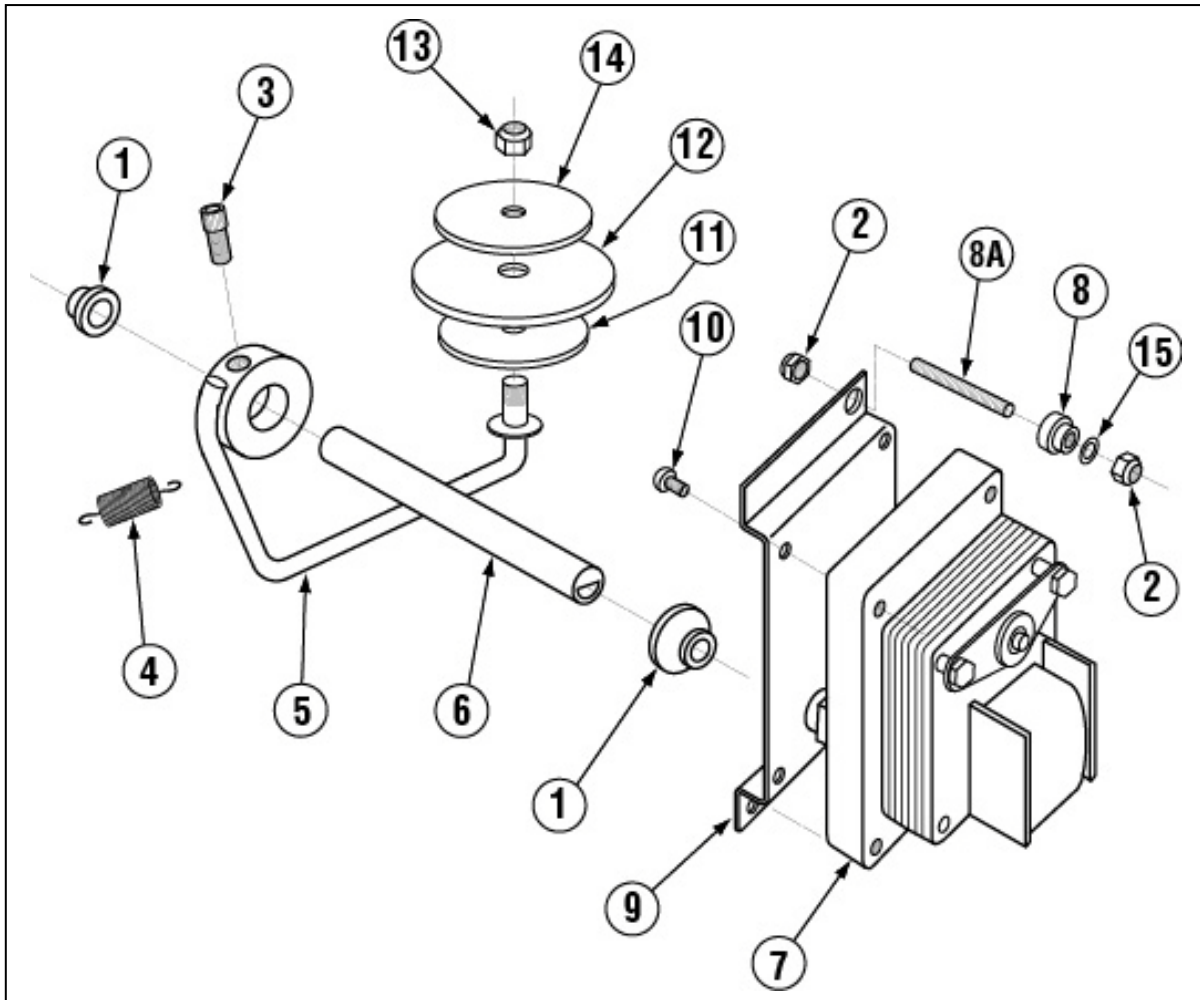

ITEM NO.	NO. REQ'D	P/N	DESCRIPTION
1	2	00938.82	1/2" Drain Bushing, Brass (V)
2	4	03801.00	10-32 Lock Nut
3	1	00906.82	1/4-20 x 5/8" Socket Head Screw
4	1	00105.82	Drain Spring (V)
5	1	00108.83	Drain Actuator Arm (includes #3)
6	1	00109.60	Drain Actuator Shaft (V)
7	1	00104.50	Drain Motor, 120V 60Hz
8	2	00109.40	Shoulder Nut, SS

ITEM NO.	NO. REQ'D	P/N	DESCRIPTION
8A	2	00109.50	10-32 x 1" Stud
9	1	01511.86	Drain Motor Bracket - 3 rd Generation
10	2	00941.00	10-32 x 5/8" Pan Head Screw
11	1	01520.82	Diaphragm Support Disk, 1-1/8"
12	1	00121.60	Drain Diaphragm
13	1	00912.00	1/4-20 Nylon Lock Nut
14	1	01521.82	Diaphragm Support Disk, 2"
15	2	04806.00	#10 Brass Washer

5.1.5. Power Drain Retrofit Kit p/n 00104.95 (11-14-07 to Current)

POWER DRAIN KIT P/N 00104.95

11-14-07

POWER DRAIN ASSEMBLY INSTRUCTIONS

1. Remove drain lid and power drain cover (see drawing B).
2. Remove hardware securing drain motor. Discard all hardware holding motor in place.
3. Remove and discard motor bracket from motor, but save two (#10) 10-32 screws.
4. Install hardware (#2, #8, #15). Thread two (#8) studs through tank and secure in place with (#2) nylon lock nuts. On the outside of tank install (#15) thin nut onto the (#8) stud and secure. **NOTE:** The (#15) thin nut serves a very important purpose in drain function.
5. From kit install new drain motor bracket to drain motor with two saved (#10) 10-32 screws.
6. Remove drain shaft by loosening (#3) screw on (#5) drain actuator arm. Discard drain shaft.
7. Install the new (#6) drain shaft from the kit and align drain actuator arm to the tank using the (#3) set screw. Make sure the flat side of the (#6) drain shaft has the (#3) set screw tightening against it.
8. Install (#4) drain spring properly on drain shaft and pay particular attention to the positioning of the long arm on spring. The long arm will rest against the top right side of drain motor bracket. (See drawing A). Install short end of spring into slot of drain shaft. (See figure C).
9. Align the shaft of the (#7) drain motor with (#6) drain actuator shaft slot as motor is placed into position. Drain motor bracket with motor attached is secured to (#8) studs using (#2) and (#17) nylon lock nuts and washers.
10. Grease the drain shaft and (#1) drain bushings. Replace drain lid and drain cover. When drain kit has been completed, energize drain several times and check its function. **NOTE:** Remove electrical spade connectors from wires leading to drain motor and replace with two (#16) flag terminals supplied in drain kit. This will allow proper clearance between drain lid and flag terminals.

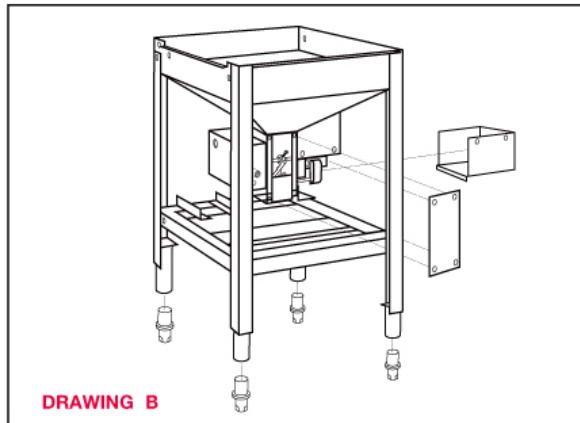
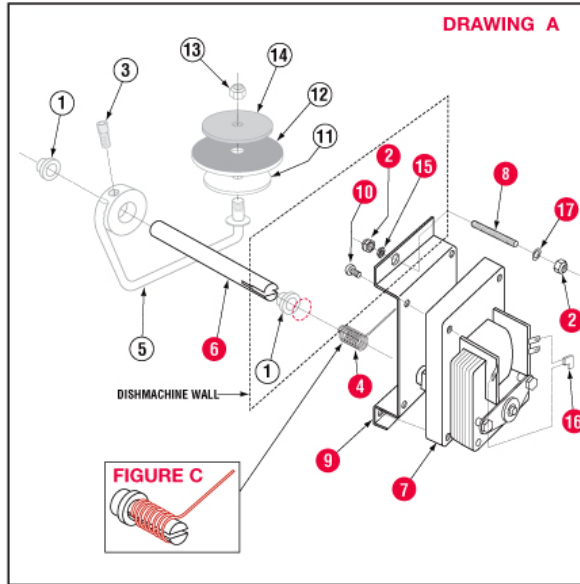

ITEM NO.	NO. REQ'D	DESCRIPTION
1	2	P/N 00938.82 Drain Bushing
2	2	P/N 03801.00 10/32 Nylon Lock Nut
3	1	P/N 00906.82 Socket Head Screw
4	1	P/N 04103.14 Drain Spring
5	1	P/N 00108.82 Drain Actuator Arm
6	1	P/N 00109.60 Drain Shaft EVA
7	1	P/N 00104.50 Drain Motor 120V
8	2	P/N 00109.50 Drain Mounting Studs
9	1	P/N 01511.86 Drain Motor Bracket
10	4	P/N 00941.00 10-32X5/8 PanHead Screw
11	1	P/N 01520.82 Support Disk
12	1	P/N 00121.60 Drain Diaphragm
13	1	P/N 00912.00 Nylon Nut
14	1	P/N 01521.82 Two Inch Support Disk
15	1	P/N 03801.20 10/32 Thin Nut
16	2	P/N 00557.20 Flag Terminal 14-16 GAUGE
17	2	P/N 00924.00 SS Washer

NOTE: Items in bold are included in the Power Drain Kit. "All items in power drain kit must be used for drain to operate properly"



12700 Knott Avenue
Garden Grove, CA 92841
For Questions Call: 800-854-6417
714-898-6781 • FAX 714-895-2141
www.cmashmachines.com

5.1.6. Peristaltic Pump Assembly

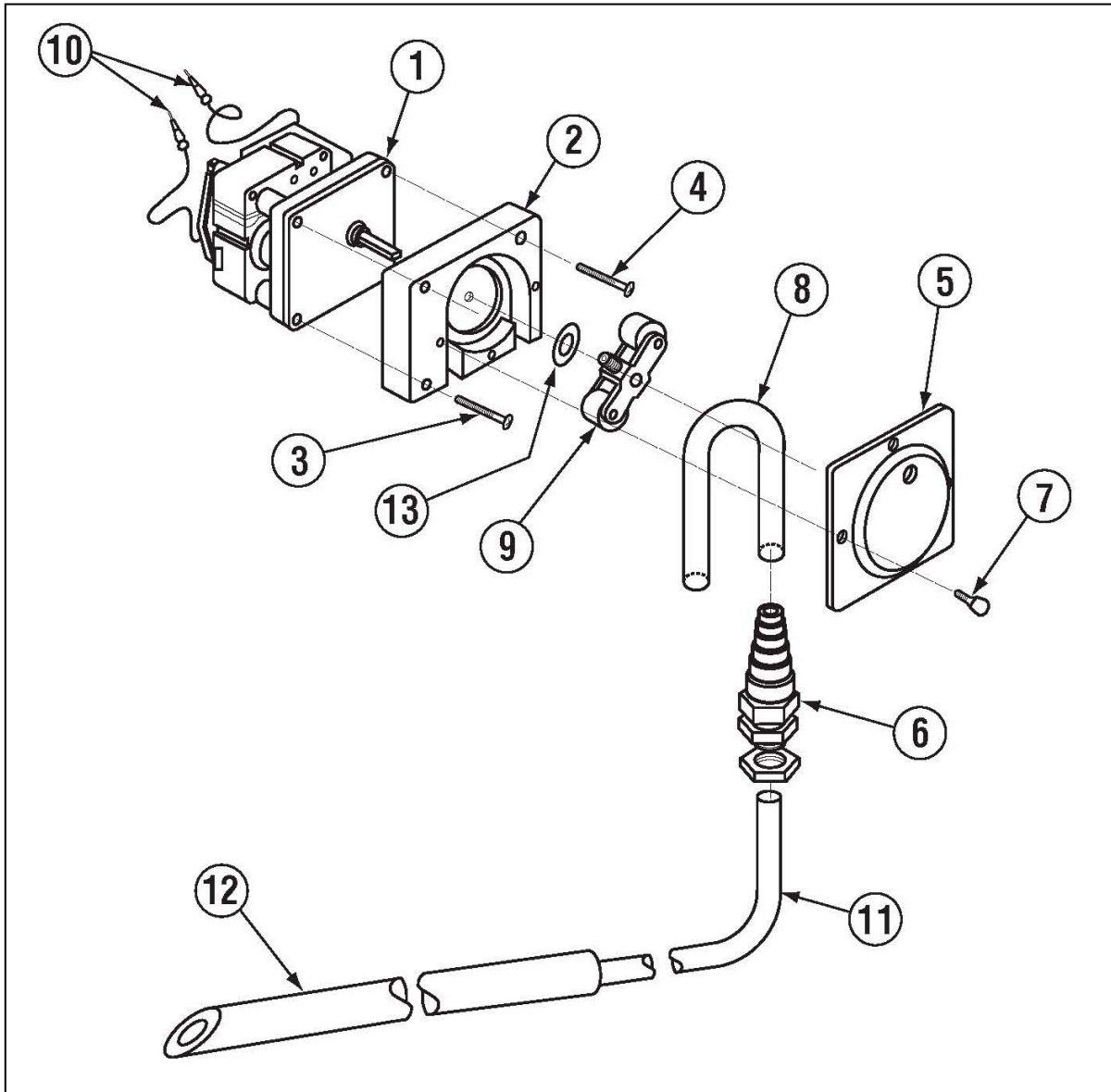

ITEM NO.	NO. REQ'D	P/N	DESCRIPTION
1	1	00416.00	Peristaltic Pump Motor
2	1	00417.10	Peristaltic Pump Block
3	2	00919.00	10-32 x 1-1/2" Pan Head Screw
4	1	00918.10	10-32 x 1-1/2" Fillister Head Screw
5	1	00418.00	Peristaltic Pump Block Cover
6	1	03415.50	Flex-Tight Fitting
7	4	00911.00	8-32 x 1/2" Pan Head Screw

ITEM NO.	NO. REQ'D	P/N	DESCRIPTION
8	1	2257.00	Squeeze Tube
9	1	00419.00	2-Bearing Rotor Assembly
10	2	00448.00	Barrel Connector, Male
11	1	00425.51	Chemical Tubing, Blue
	1	00425.53	Chemical Tubing, Red
	1	00425.54	Chemical Tubing, White
12	3	00443.00	Tube Stiffener
13	1	00422.50	Rotor Spacer

5.1.7. Temp – Sure Heater

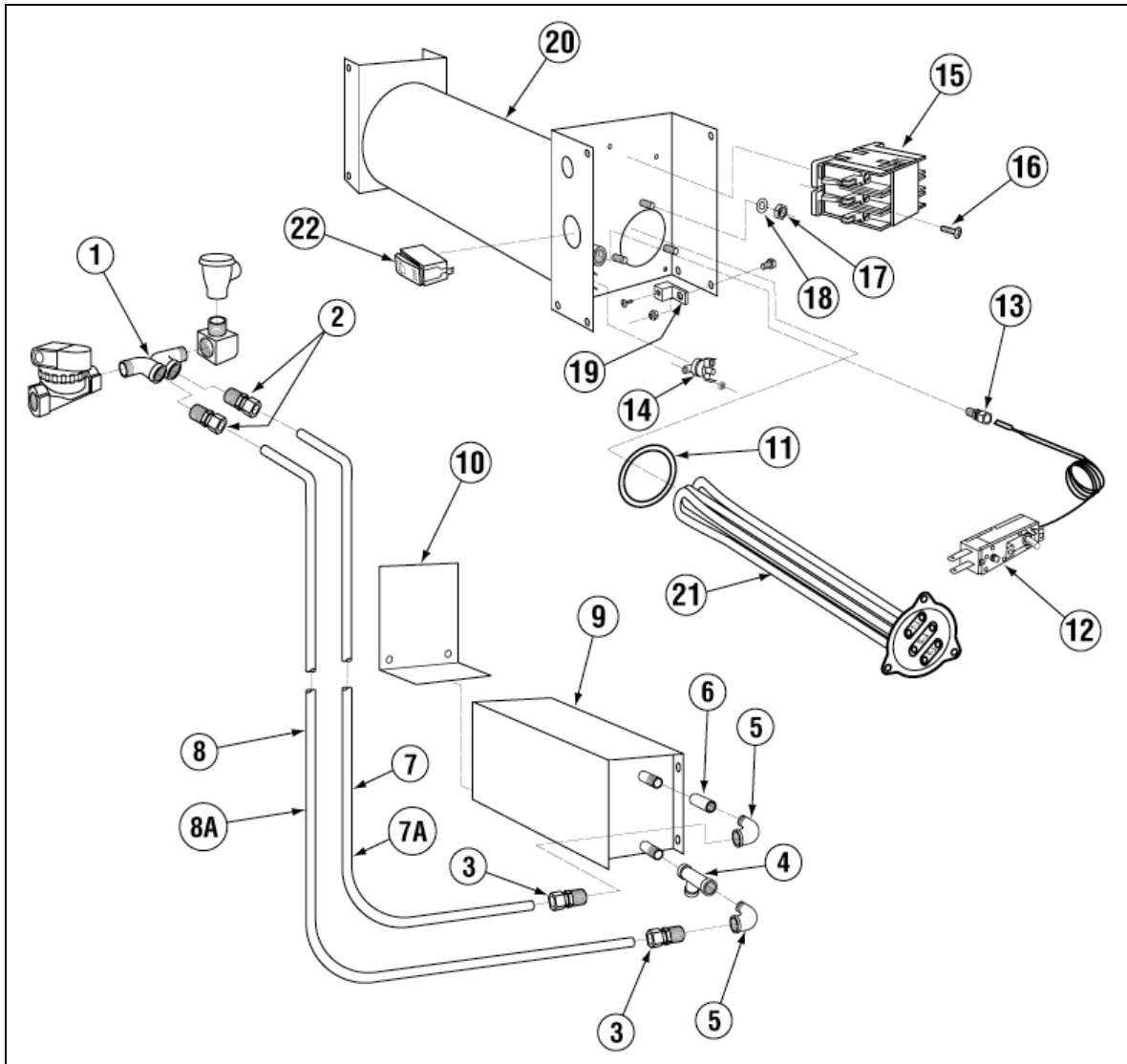

ITEM NO.	NO. REQ'D	P/N	DESCRIPTION
1	1	13633.20	Booster Heater 3/4" in/out Adapter
2	2	00761.00	5/8" Comp. x 3/4" MIP Adapter
3	2	00760.00	5/8" Comp. x 1/2" MIP Adapter
4	1	00743.10	1/2" Tee FxFxF Brass
5	1	13620.00	1/2" S.S. Street Elbow
6	1	13618.00	1/2" S.S. Coupling
7	1	N/A	Tempsure Discharge Line for AH
7A	1	N/A	Tempsure Discharge Line for C
8	1	N/A	Tempsure Intake Line for AH
8A	1	N/A	Tempsure Intake Line for C
9	1	01594.20	3 Sided Heater Tank Shield
10	1	01594.10	Booster Heater Tank Access Cover

ITEM NO.	NO. REQ'D	P/N	DESCRIPTION
11	1	15518.11	Gasket for Triangular Flange Heater
12	1	13417.92	Thermostat for 12 KW Heater (EGO)
13	1	40116.00	1/4 Comp x 1/4 MIP Fitting
14	1	17523.51	Hi-Limit Switch 250 Deg.
15	1	13003.17	Contactor 60 Amp 3 Pole
16	2	00941.00	10-32x5/8" Panhead Screw
17	11	00912.00	1/4-20 Nylon Lock Nut
18	3	00924.00	1/4" S.S. Washer
19	1	13426.50	Ground Block
20	1	01595.40	Heater Tank for Tempsure
21	1	13422.71	240V 12KW Triangular Immersion Htr
22	1	00421.83	CMA-44 Rocker Switch White

6. Electrical Diagram

