



EST-FL (FRONT LOADER)

Chemical Sanitizing
Single Rack
Dishmachine



EST-FL
(Front Loader)
Without
Hot water
Assurance
System
P/N:1614.50

EST-FL
(Front Loader)
With
OPTIONAL
Hot water
Assurance System
P/N:1614.00



CMA Front Skirt
available as option.
P/N:1512.30

Features:

- 75% less floor space than traditional Dishmachines (compact space-saving design)
- Standard 20"X20" racks
- Requires only 5.06 sq ft of floor space
- Front loading door design provides optimal working height for easy loading and unloading of dishes
- 90 sec cycle (40 racks per hour)
- Energy Star water saving design uses only 1.09 gallons of water per cycle
- Standard 115v electrical circuit
- Powerful Stainless Steel pump with Upper and Lower Wash Arms
- Pumped fresh water rinse system
- Low-temp chemical sanitizing system which requires minimum 120 degree, ideal 140 degree water supply
- Top mounted controls with automatic 3-product dispensing system
- Large 16" dish clearance height
- Interchangeable components compatible with other CMA products
- Built-in scrap accumulator
- Inside sump design
- ETL/UL/Energy Star Certified

Available Options

- Built-in Hot Water Assurance System provides hot water every cycle
- Sanitizer Alarm
- CMA Front Skirt

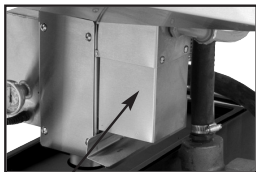

Internal power drain saves space, quiet activation. Drains quickly.

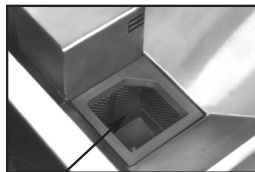

Self cleaning pump screen prevents service calls.

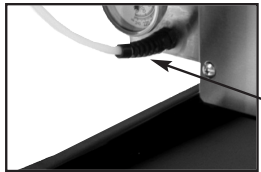

Unique sanitizing system sanitizer injector is located close to pump, allowing sanitizing to take place immediately. Strategic location eliminates chlorine damage to the machine.

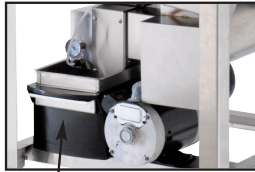

Built-in "Poly Pro"™ scrap accumulator. With Stainless Steel tray and cover.

**CMA
MIZER**®
Registered Trademark



BCI
PROFESSIONAL
800.577.6202 • www.BCIchem.com



EST-FL (FRONT LOADER)

Chemical Sanitizing
Single Rack
Dishmachine

WARNINGS:

- Plumbing connections must be made by a qualified service company who will comply with all available Federal, State, and Local Health, Plumbing and Safety codes.
- Water hardness above 3 grains per gallon should be treated by a water softener. Failure to provide soft water (3g or less) will void the machine warranty.

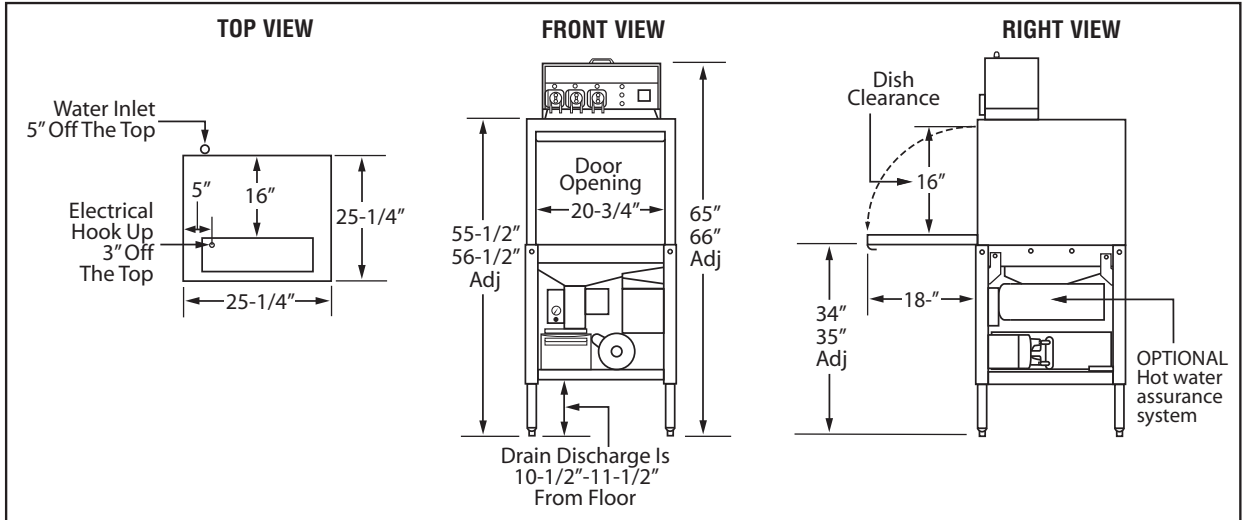

Specifications:

MODEL EST	USA	METRIC		USA	METRIC
WATER CONSUMPTION			FRAME DIMENSIONS		
PER RACK	1.09 GAL.	(4.12L)	DEPTH	25-1/4"	(64.1cm)
PER HOUR	43.6 GPH	(165 L)	WIDTH	25-1/4"	(64 cm)
WATER INLET	1/2"	(1.27cm)	HEIGHT	55-1/2"-56-1/2"	(141.2cm-143.5cm)
DRAIN	2"	(5.1cm)	MAXIMUM CLEARANCE HEIGHT FOR DISHES	16"	(43.2cm)
OPERATING CYCLE			STANDARD DISHRACK		
WASH TIME - SEC.	53	53	DIMENSIONS	19-3/4"X19-3/4"	(50X50cm)
RINSE TIME - SEC.	30	30	WASH PUMP MOTOR HP		
DWELL	7	7	1		
TOTAL CYCLE	90	90	ELECTRICAL RATING		
OPERATING CAPACITY			VOLTS		
RACKS PER HOUR	40	40	115		
WASH TANK CAPACITY			AMPS		
1.09 GAL. (4.12 L)			16		
PUMP CAPACITY			SHIPPING WEIGHT		
52 GPM (197 LPM)			APPROXIMATE		
OPERATING TEMPERATURE			273# (124 kg)		
REQUIRED	120°F	(49°C)			
RECOMMENDED	140°F	(60°C)			

Summary Specifications: Model EST Front Loader

The Energy Mizer model EST FRONT LOADER low temperature, chemical sanitizing commercial dishwasher meets UL Electrical and ETL Sanitation (NSF Standard 3) standards. Model EST FRONT LOADER is constructed entirely of stainless steel. Each unit automatically washes, rinses and sanitizes food service utensils in standard 20" x 20" racks. Unit comes with upper and lower stainless steel wash arms.

Advisory: CMA does NOT endorse "Tankless On-Demand" water heaters for use on CMA Dishmachine products. CMA DOES endorse, and highly recommends, the standard "tank" style water heaters, sized properly to handle each particular facility with their water heating requirements.



800.577.6202 • www.BCIchem.com