



LOW TEMPERATURE UNDERCOUNTER GLASSWASHER

L-1C

Low Temperature Undercounter Glasswasher



CMA MODEL: L-1C

Introducing CMA's "Noise Suppression Technology" combining sophisticated pump engineering, double wall construction and sound deadening materials has reduced noise output to 50%, without sacrificing horse power or pump pressure. This is the ideal "behind the bar" glasswasher providing outstanding results, economical water usage and quiet operation. This glasswasher utilizes a recirculating wash system followed by a fresh water chemical sanitizing rinse. The built in chemical dispensing system is programmable to provide precise chemical dosage per cycle.



Universal Pedestal



CMA Temp-Sure
(Self contained 12kW heater)

FEATURES

- New Noise Suppression Technology (NST).
- 30 racks / 120 covers per hour.
- Economical to operate. Uses only 1.7 gallons of water per cycle.
- All stainless steel construction assures long life and years of trouble-free operation.
- Unique spray arm system features upper and lower stainless steel wash arms with reinforced end caps.
- Double skin stainless steel provides consistent heating and a quiet operation.
- Built-in chemical pumps assure proper chemical usage.
- Deliming system.
- Pumped drain allows for flexible installation. Requires no floor drain.
- Pump purging system improves results by eliminating soil and chemical carryover during rinse cycle.
- Water inlet comes with built-in strainer, prevents debris from clogging the water valve.
- 4" Stainless Steel Legs.
- Dishmachine comes with 2 dishracks, (1) peg and (1) flat.
- Large 11" door clearance to accommodate all size glasses.
- Sustainer Heater.

AVAILABLE OPTIONS

- Low Chemical Alarm
- 48" Undercounter Dishtable
- 6" Stainless Steel Legs
- Roller Casters
- Drain Board



Chemical Sanitizing Glasswasher

WARNINGS:

- Plumbing connections must be made by a qualified service company who will comply with all available Federal, State, and Local Health, Plumbing and Safety codes.
- CMA recommends utilizing a water softening system to maintain water hardness measurements of 3.5 gpg (grains per gallon) or less. This will assure maximum results and optimum operation of the dishmachine.

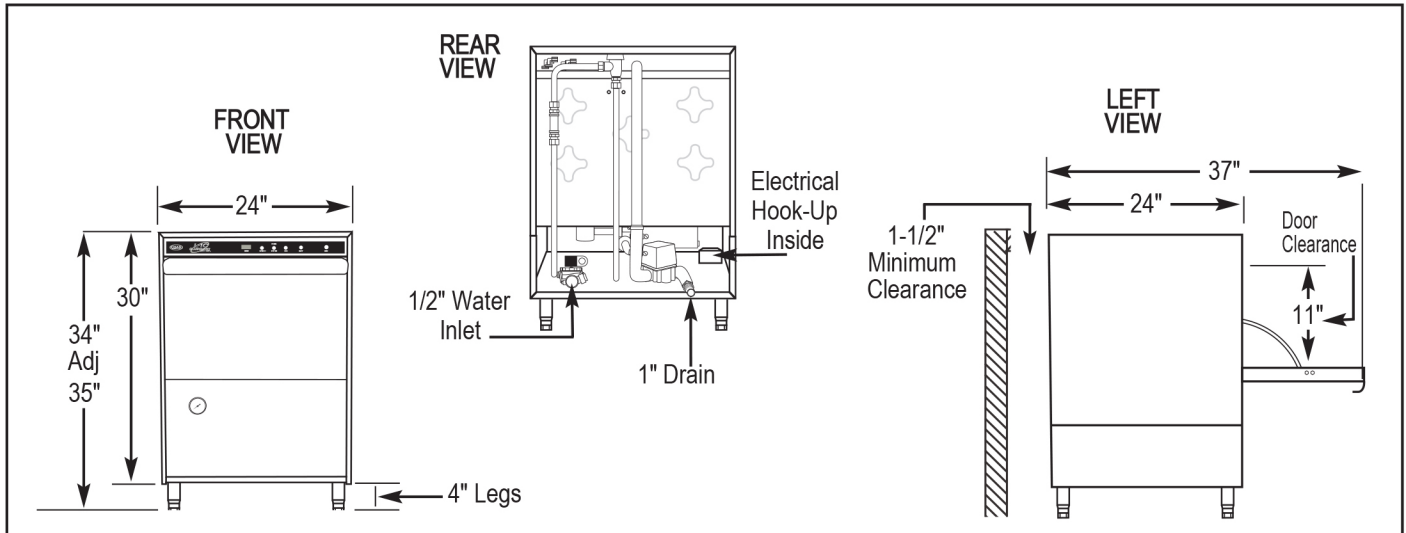

Specifications:

MODEL L-1C	USA	METRIC		USA	METRIC
OPERATING CAPACITY			WASH PUMP MOTORS HP	1	1
RACKS PER HOUR (NSF RATED)	30	30	DIMENSIONS		
OPERATING CYCLE			DEPTH	24"	(61cm)
WASH TIME-SEC	58	58	WIDTH	24"	(61cm)
RINSE TIME-SEC	32	32	HEIGHT	34"-35"	(86.3-88.9 cm)
DWELL/PURGE-SEC	30	30	MAXIMUM CLEARANCE HEIGHT FOR GLASSES	11"	(28cm)
TOTAL CYCLE TIME	2 MIN	2 MIN	STANDARD DISHRACK	1	1
WASH TANK CAPACITY	1.7 GAL.	(6.43 L)	DIMENSIONS	20" x 20"	(50.8 x 50.8cm)
WASH PUMP CAPACITY	35 GPM	(132 LPM)	ELECTRICAL RATING	VOLTS	AMPS
OPERATING TEMPERATURE				115	16
REQUIRED	120°F	(49°C)	APPROXIMATE SHIPPING WEIGHT	203#	(92kg)
RECOMMENDED	140°F	(60°C)	SHIPPING DIMENSIONS	PALLET & BOX @ 29" X 28" X 38"	
WATER CONSUMPTION					
PER RACK	1.7 GAL.	(6.43 L)			
PER HOUR	51 GPH	(192.9 LPH)			
WATER INLET	1/2"	(1.27cm)			
DRAIN	1"	(2.54cm)			

Summary Specifications: Model L-1C

CMA model L-1C, low temperature, undercounter, chemical sanitizing, commercial glasswasher meets NSF, UL and CUL sanitation and construction standards WITHOUT the use of BOOSTER or TANK HEATERS. The model L-1C is constructed entirely of stainless steel. Automatically washes, rinses and sanitizes food service utensils in standard 19-3/4"X19-3/4" racks. This model comes standard with upper and lower stainless steel wash arms. The L-1C incorporates a pump purging system that improves results by eliminating soil and chemical carryover during rinse cycle.

New Innovative Noise Suppression Technology (NST)

Advisory: CMA does NOT endorse "Tankless On-Demand" water heaters for use on CMA Dishmachine products. CMA DOES endorse, and highly recommends, the standard "tank" style water heaters, sized properly to handle each particular facility with their water heating requirements.

CMA MIZER[®]
Registered Trademark



BCI
PROFESSIONAL
800.577.6202 • www.BCIchem.com