



MODEL E ENERGY SAVER
LOW WATER
MACHINES

**USES ONLY
1.01
Gallons Of Water
Per Cycle!**



**MODEL E
AVAILABLE IN STRAIGHT
AND CORNER MODEL**



**OPTIONAL 3 DOOR
MODEL AVAILABLE
FOR STRAIGHT AND
CORNER OPERATION**



**MODEL E EXT
WITH 20-1/2" DOOR OPENING
AVAILABLE IN STRAIGHT
AND CORNER MODEL**

FEATURES AND FACTS:

- **Energy Star Qualified.**
- 40 racks / 160 covers per hour.
- Economical to operate. **Uses only 1.01 gallons of water per cycle.**
- All stainless steel construction assures long life and years of trouble free operation.
- Unique spray arm system features upper and lower stainless steel wash arms with reinforced end caps.
- Top mounted controls include built-in chemical pumps and deliming system for dealing with scale.
- Auto start/stop makes operation safe and easy.
- New integrated scrap tray prevents food soil from entering drain system.
- Airgap fill system.

CONVERTIBLE CORNER TO STRAIGHT AND STRAIGHT TO CORNER.

Available Options

- Sanitizer Alarm
- Alternative cycle times
- Pull Pins
- Stainless Steel Scrap Trap Up Grade
- The "TEMP-SURE" requires a separate 208-240v 3 phase 40 amp power supply
- 3 Doors open
- Extended (Tall) version



800.577.6202 • www.BCChem.com





MODEL E ENERGY SAVER
LOW WATER
MACHINES

WARNINGS:

- Plumbing connections must be made by a qualified service company who will comply with all available Federal, State, and Local Health, Plumbing and Safety codes.
- Water hardness above 3 grains per gallon should be treated by a water softener. Failure to provide soft water (3g or less) will void the machine warranty.

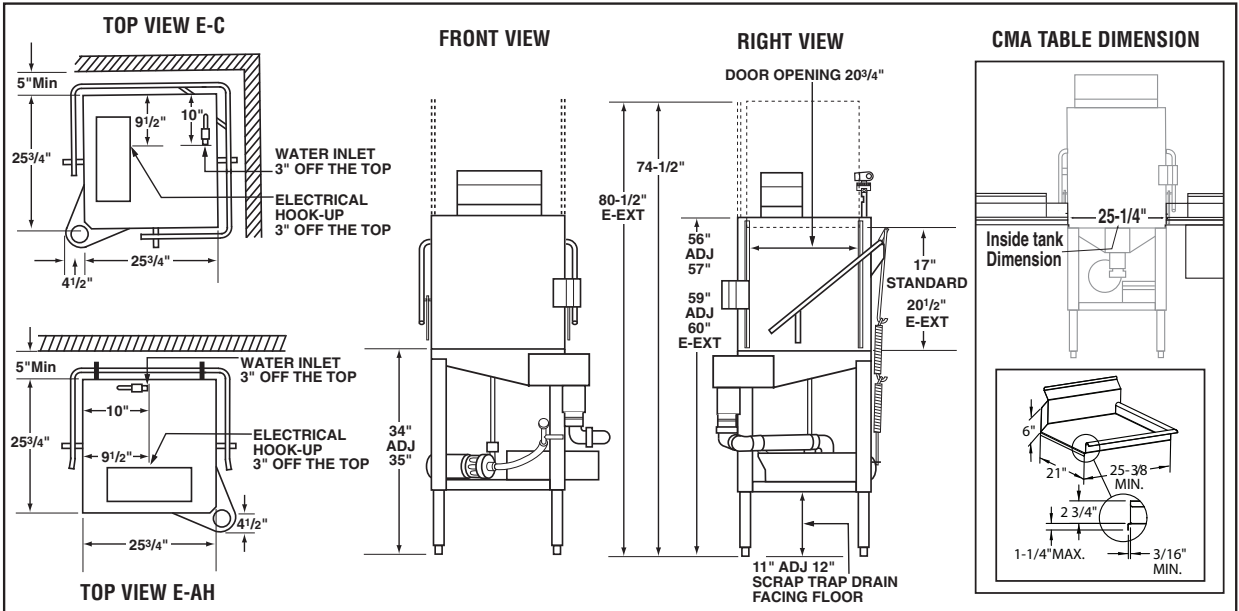

Specifications:

MODEL E/E-3/E-EXT	USA	METRIC		USA	METRIC
OPERATING CAPACITY			WASH PUMP MOTORS HP	1	1
RACKS PER HOUR (NSF RATED)	40	40	DIMENSIONS		
OPERATING CYCLE			DEPTH	25-3/4"	(65.4cm)
WASH TIME-SEC	45	45	WIDTH (OUTSIDE DIMENSION)	25-3/4"	(65.4cm)
RINSE TIME-SEC	30	30	HEIGHT	56"-57"	(142.2cm-144.8cm)
DWELL TIME-SEC	15	15	E-EXT 59"-60"		(150cm-152cm)
TOTAL CYCLE TIME	90	90	STANDARD TABLE HEIGHT	34"	(86cm)
PUMP CAPACITY	52 GPM	(197 LPM)	MAXIMUM CLEARANCE FOR DISHES	17"	(43cm)
OPERATING TEMPERATURE			E-EXT 20-1/2"		(52cm)
REQUIRED	120°F	(49°C)	STANDARD DISHRACK DIMENSIONS	1	1
RECOMMENDED	140°F	(60°C)	19-3/4"X19-3/4"		(50X50cm)
WATER CONSUMPTION			ELECTRICAL RATING	VOLTS	AMPS
PER RACK	1.01 GAL.	(13.79 L)		115	16
PER HOUR	37 GPH	(139 LPH)	SHIPPING WEIGHT APPROXIMATE		
WATER REQUIREMENTS			218#		(98.7kg)
WATER INLET	1/2"	(1.27cm)	E-EXT L 260#		(117.8kg)
DRAIN-I.P.S.	2"	(5.1cm)			

Summary Specifications: Model E/E-3/E-EXT

CMA Energy Miser model E/E-3/E-EXT(Extended 20-1/2" door opening) low temperature, chemical sanitizing commercial dishwashers meet ETL, UL, and CUL sanitation and construction standards WITHOUT the use of BOOSTER or TANK HEATERS. The model E/E-3/E-EXT is constructed entirely of stainless steel. Each unit automatically washes, rinses and sanitizes utensils in standard 19-3/4"x19-3/4" racks. Units come with standard upper and lower stainless steel wash arms. **Note: This machine does not have built-in heaters, therefore produces no steam.**

Advisory: CMA does NOT endorse "Tankless On-Demand" water heaters for use on CMA Dishmachine products. CMA DOES endorse, and highly recommends, the standard "tank" style water heaters, sized properly to handle each particular facility with their water heating requirements.

